

# Audio amplifier Zita (Z) bridge NEW

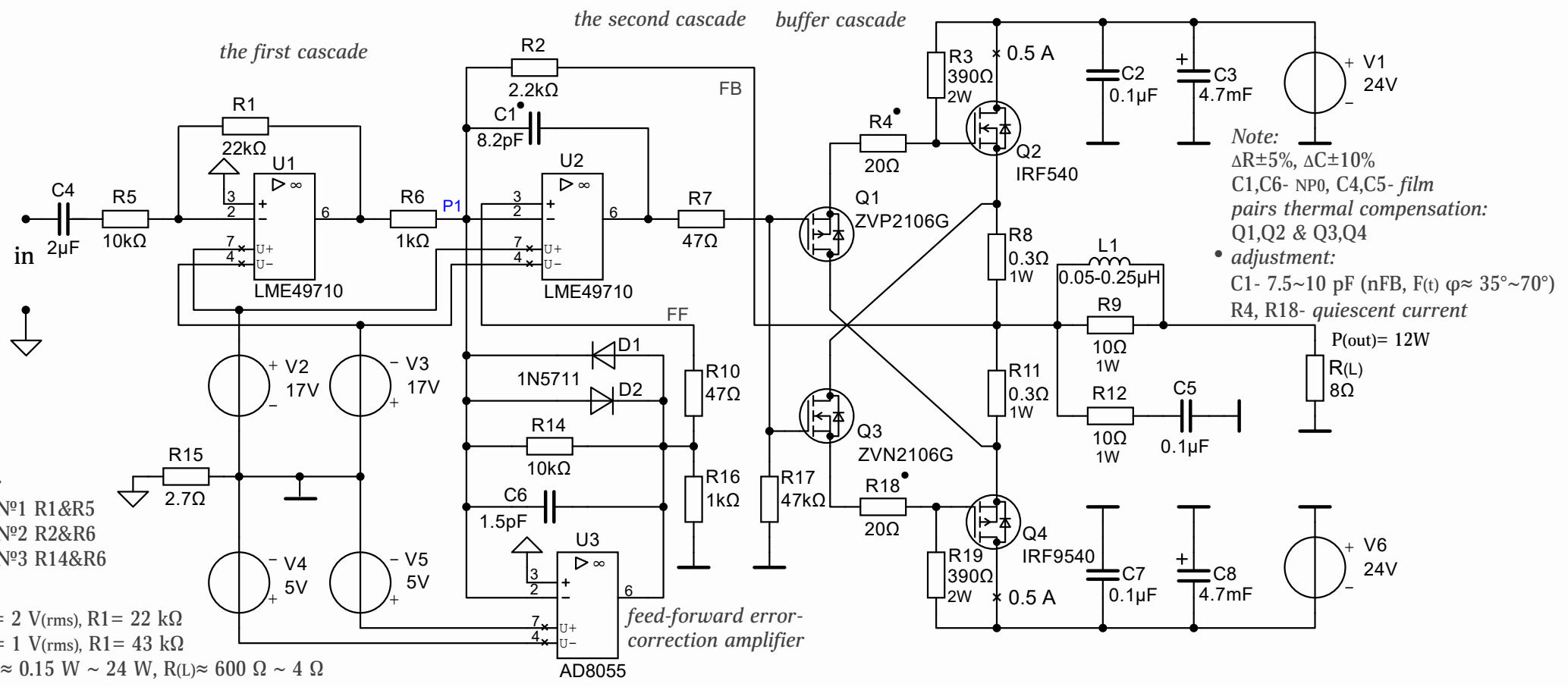

## Features:

- high fidelity audio operational amplifier LME49710
- feed-forward error-correction amplifier AD8055
- buffer cascade (Q1~Q4) "bridge+1\2 bridge, class-A"
- smart overload protection "step by step" (SoP)
- ripple rejection < -100 dB power supply

## Key specifications:

$F_{(-3dB)}$  10 Hz ~ 10 MHz  
 $F_{(-1dB)}$  15 Hz ~ 6 MHz  
 $F_{(\varphi < 30^\circ)}$  15 Hz ~ 2.7 MHz  
 $F_{(\varphi < 5^\circ)}$  90 Hz ~ 450 kHz  
 $P_{(-3dB)}$  10 Hz ~ 450 kHz

$P_{(out)} > 3 \text{ W}$  (buffer, class-AB)  
 $P_{(out)} \leq 3 \text{ W}$  (buffer, class-A)  
 THD  $\leq 0.001 \%$  (10 Hz~10 kHz)  
 SINAD  $\approx 93 \text{ dB}$  (10  $\mu\text{W}$ ~10 W)  
 $P_{(out)} \approx 15 \text{ W}$ , max. (THD  $\approx 1\%$ )

Note:  $P_{(out)} \approx 10 \text{ W}$ ,  $R_{(L)} = 8 \Omega$

**SPICE**  
Models

ID: 8144715A



submit  
documentation feedback



A two-stage power amplifier for speakers and stereo phones.

**The first cascade. U1**

Inverting voltage amplifier.

G ~ 7 dB

Z<sub>(in)</sub> ~ 10 kΩ

F<sub>(-3dB)</sub> 10 Hz ~ 23 MHz

F<sub>(t)</sub> ~ 40 MHz

**The second cascade. U2 U3 Q1~ Q4**

Inverting voltage amplifier (U2), error voltage amplifier (U3).

U2

G ~ 7 dB

Z<sub>(in)</sub> ~ 1 kΩ

F<sub>(-3dB)</sub> ~ 13 MHz

F<sub>(t)</sub> ~ 21 MHz

U3

G ~ 71 dB

F<sub>(-3dB)</sub> ~ 40 kHz

F<sub>(t)</sub> ~ 150 MHz

The error voltage from point "P1" is amplified, inverted by U3 and summed with the voltage at point "P1" in the differential cascade U2.

The error correction amplifier increases the gain in the loop (LG) to LG+71 dB, F<sub>(-3dB)</sub> ≈ 40 kHz.

The diode limiter (D1,D2) reduces the gain in the error correction amplifier (U3) and U2 with significant signal addition errors at the point "P1". Addition errors at point "P1" will occur when the input amplifier is overloaded or when complex signals are amplified (meander).

**Buffer cascade (Q1~ Q4)**

G ~ -0.9 dB

Z<sub>(in)</sub> ~ 47 kΩ

F<sub>(-3dB)</sub> ~ 40 MHz

P<sub>(-3dB)</sub> ~ 3.5 MHz

The "bridge+1/2 bridge" circuit operates with a quiescent current of 0.5 A in the "class-A" mode, P<sub>(out)</sub> ≤ 3 W, R<sub>(L)</sub> = 8 Ω.

Parametric voltage regulator V2~V5.

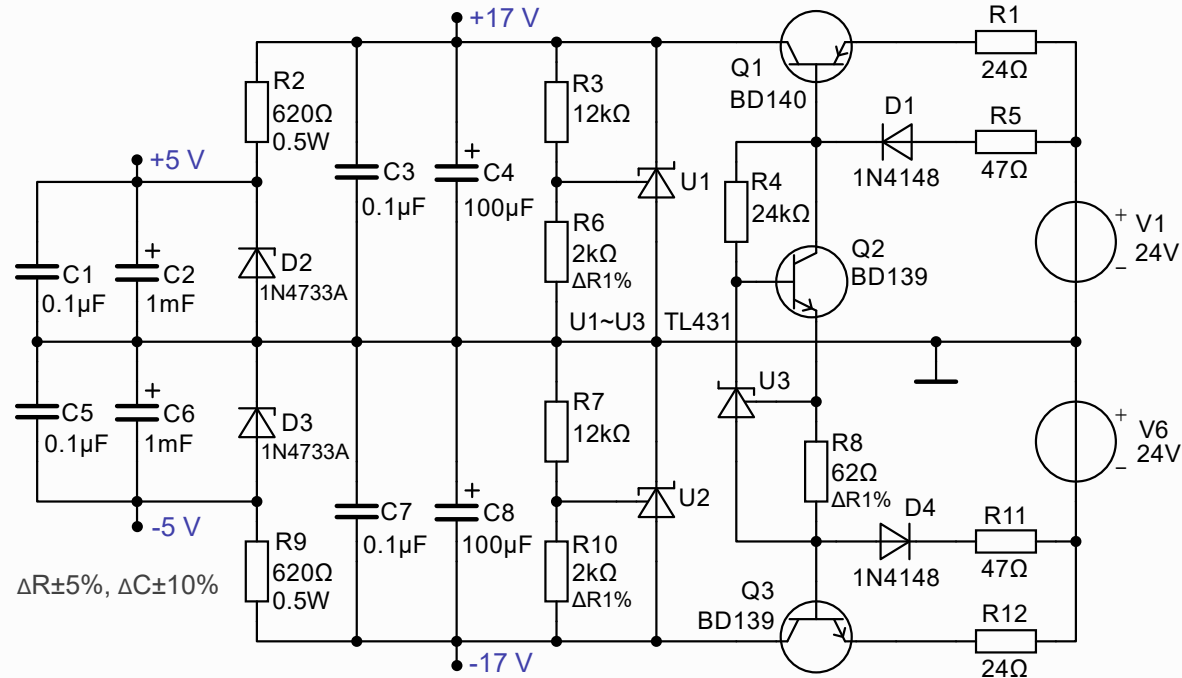

Bipolar power supply with parametric voltage stabilization, calculated value of the voltage attenuation value interference (ripple rejection) <math>< -100\text{ dB}</math> in the bandwidth of voltage stabilization channels.

Short circuit protection of the stabilizer output.

High precision output voltage ( $U_{REF(dev)} = 2.495\text{ V} \pm 3\text{ mV}$  (type.)) and good thermal stability ( $\alpha U_{(ref)} < 50\text{ ppm}/^\circ\text{C}$ ) reference voltage sources in a wide range of temperature values.

The value of the dynamic and static output impedances of voltage regulators  $Z_{(ka)} < 0.22\ \Omega$  (type.).



# Audio amplifier Zita (Z) bridge

*A power amplifier with combined feedback (FB & quasi-FF)\**

*The use of combined feedback improves the technical characteristics of the amplifier.*

*Voltage feedback (FB) works well in stationary mode, when amplifying smooth-shaped signals (sinusoidal signal).*

*Direct voltage coupling (FF) works well in non-stationary mode, when complex signals of a non-smooth shape (meander) are amplified.*

## Advantages:

*Expansion of the effective bandwidth of the amplifier ( $F_{(-3dB)}$ ).*

*Improvement of the impulse response of the amplifier.*

*Reduction of nonlinear distortion (THD) and intermodulation distortion (IMD).*

*Increasing the stability of the amplifier to the reactive impedance of the load ( $C_{(L)}$ ).*

*Improving the stability of DC operating points in the amplifier stages.*

*Bandwidth  $F \approx 2.7$  MHz with a phase shift of  $< 30^\circ$  and good low-signal linearity makes it possible to amplify up to  $F \approx 10\sim 20$  kHz almost the full spectrum of smooth signals with minimal changes in their spectral composition.*

*The diode limiter (D1,D2) eliminates overload of the amplifier stages in case of short breaks in the feedback loop (nonlinear cascade operation) and overload of the input signal.*

*The error amplifier (U3) operates with a gain of  $G \approx 70$  dB in linear mode of operation of the amplifier, in overload mode the gain decreases exponentially and amounts to  $G \ll 0$  dB.*

*Tracking Trend*

*\* Additional information is provided in the publication:*

*"Feedforward error correction in power amplifiers. J. Wanderkooy".*

*Zita (Z) simplified architecture*

*the first cascade    the second cascade    buffer cascade*

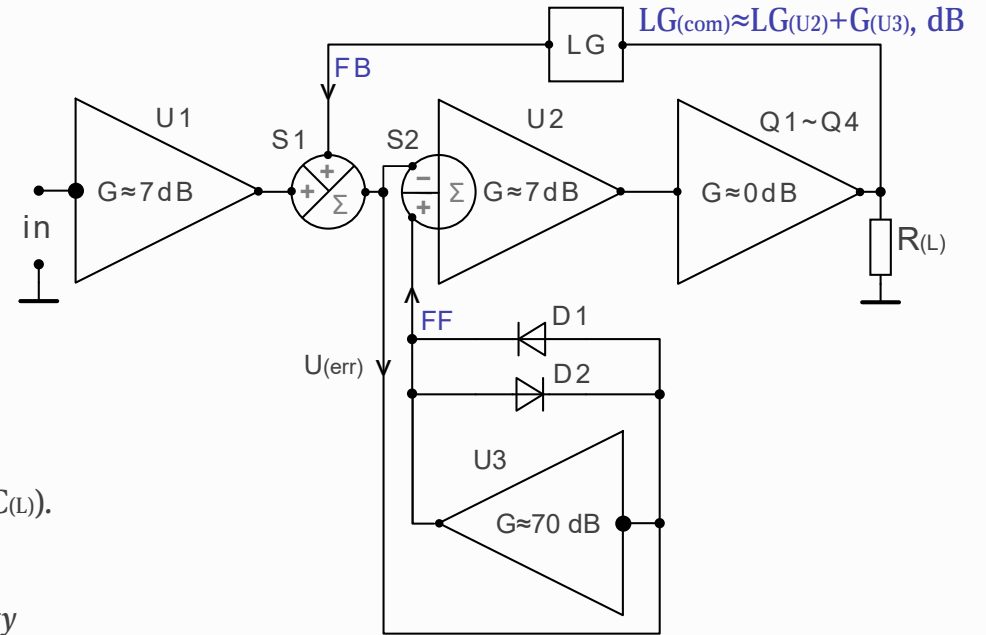

*feed-forward error-correction amplifier*

*S1- adder, point "P1" (nFB №2 R2&R6)*

*S2- U2, differential stage works as a adder*

*U(err)- error voltage, point "P1"*

*G- the voltage gain factor*

*LG- feedback loop gain*

*Note:*

*Direct communication is located inside the feedback loop.*

# Smart overload protection (SoP)

## Zita (Z) architecture SoP Block diagram

Performing the "step by step" procedure allows you to correct errors in the feedback loop more effectively and improve the accuracy of signal amplification.

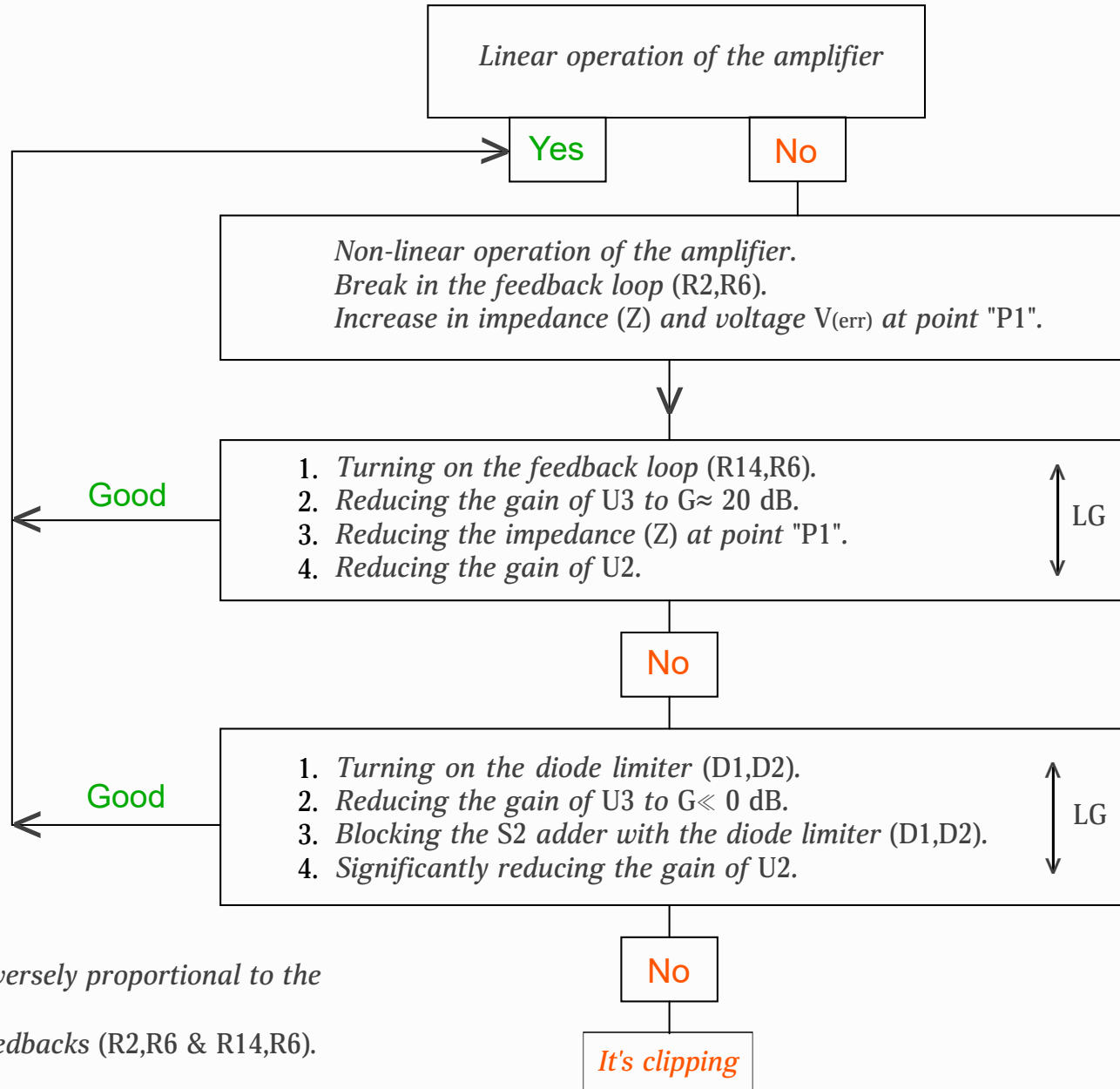

### Note:

The impedance (Z) at point "P1" is inversely proportional to the gain in the feedback loop.

Point "P1" will be common to both feedbacks (R2,R6 & R14,R6).

LG- Feedback loop gain.



# AC Sweep Open loop gain (OLG)

$$\frac{\Delta U_{(out)}}{\Delta U_{(in)}}$$

Figure 1

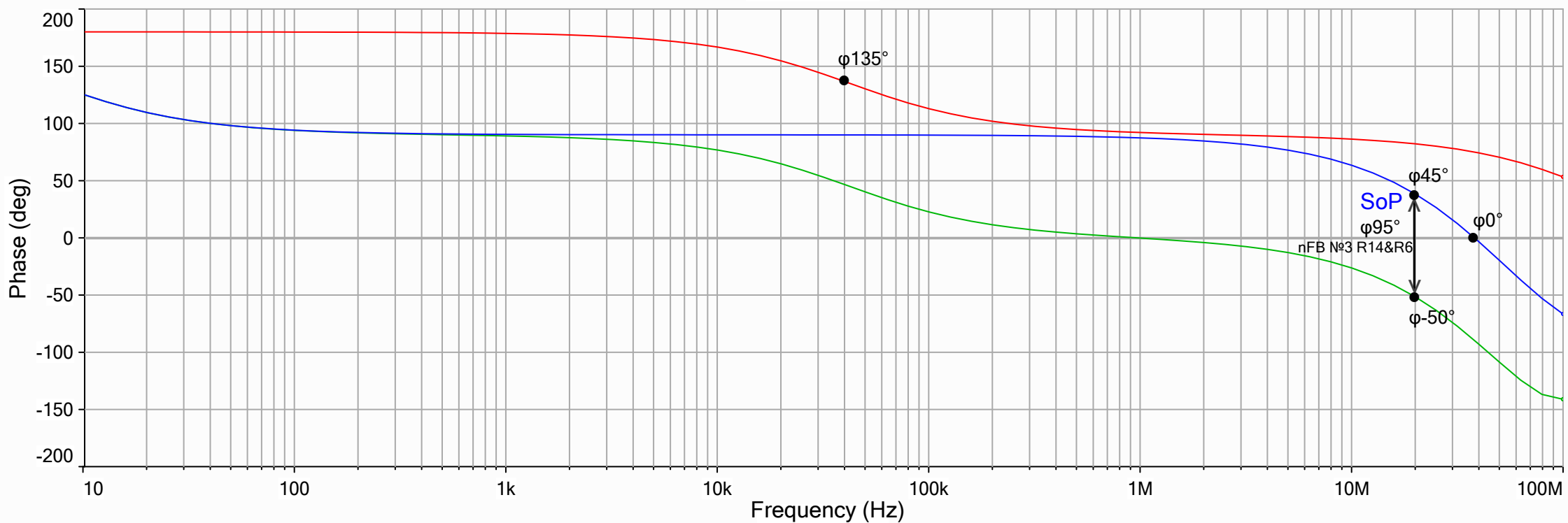
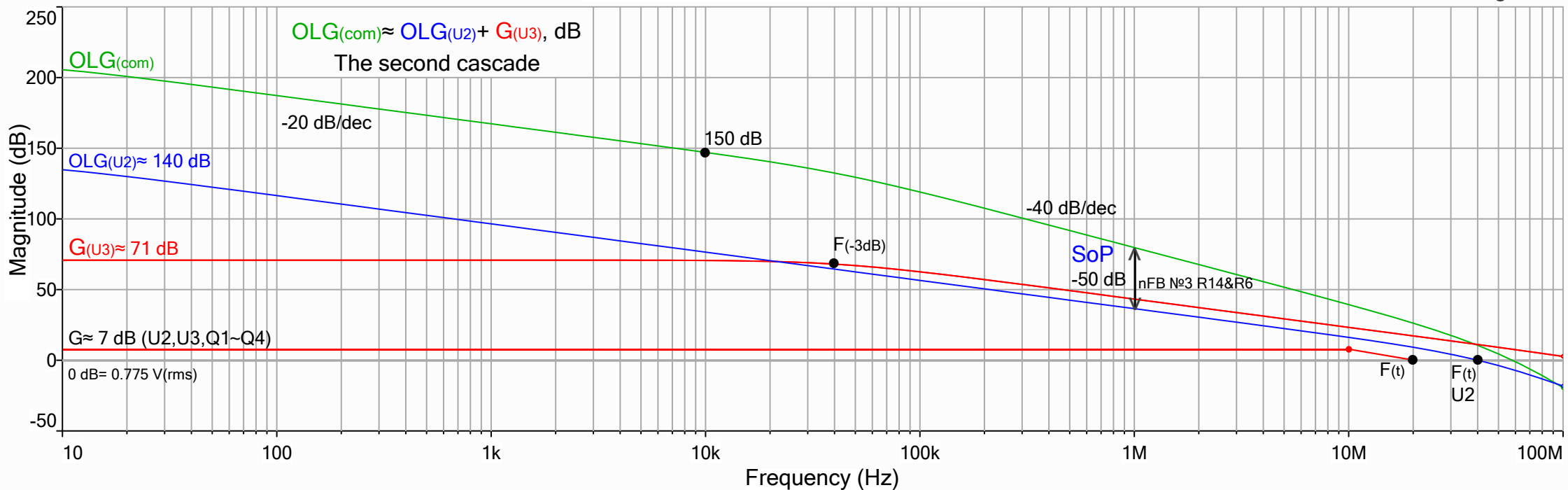

# Spectrum analysis

Figure 2

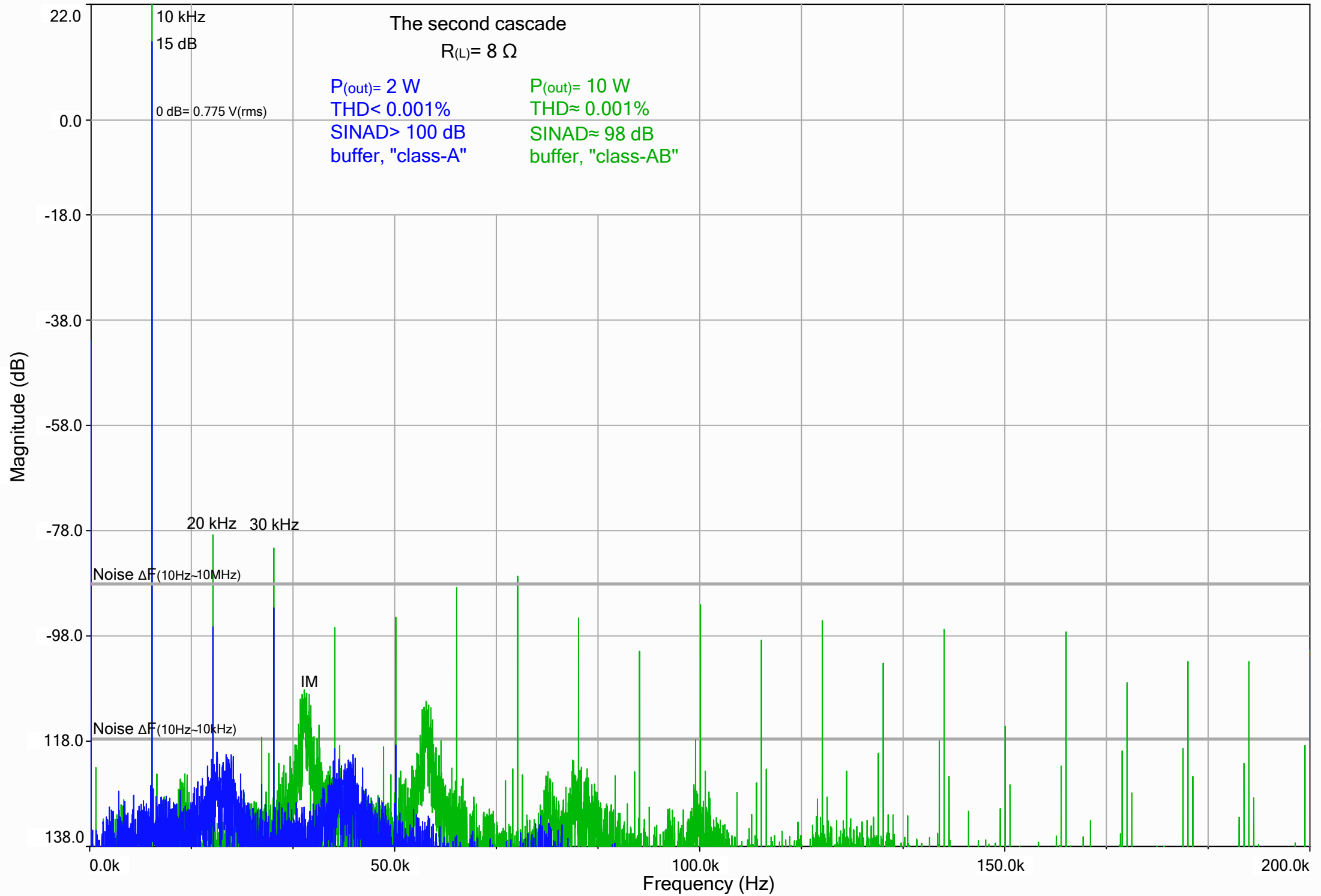

# AC Sweep Error-correction amplifier U3

$$\frac{\Delta U_{(out)}}{\Delta U_{(in)}}$$

Figure 3

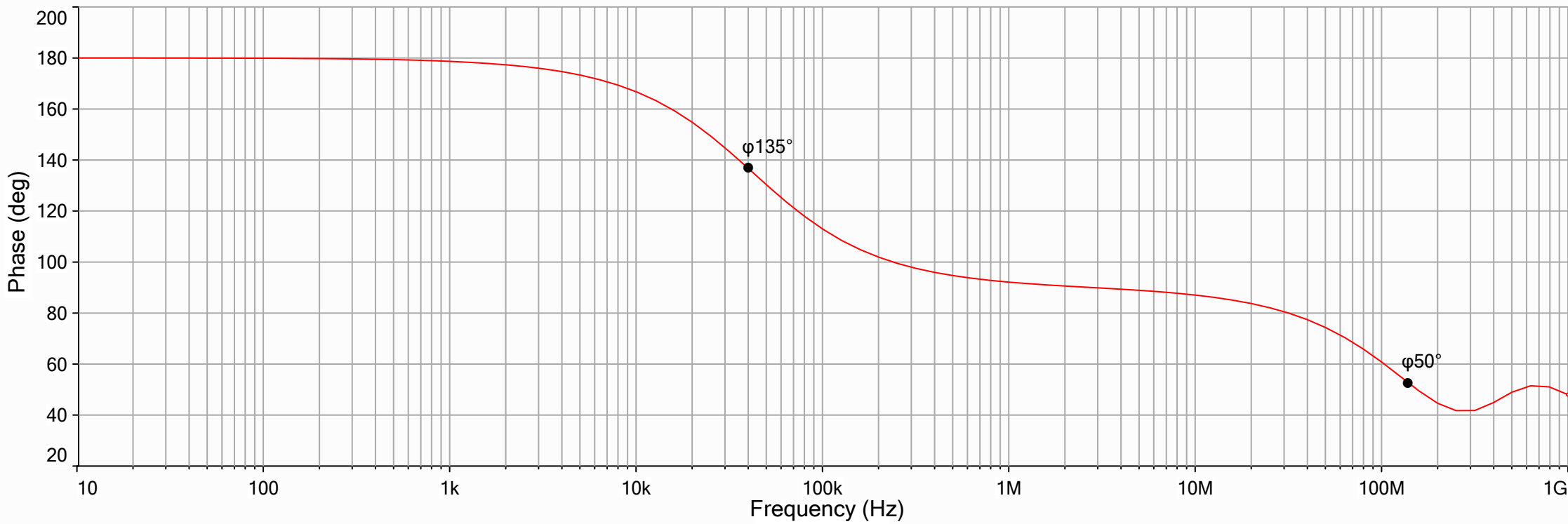
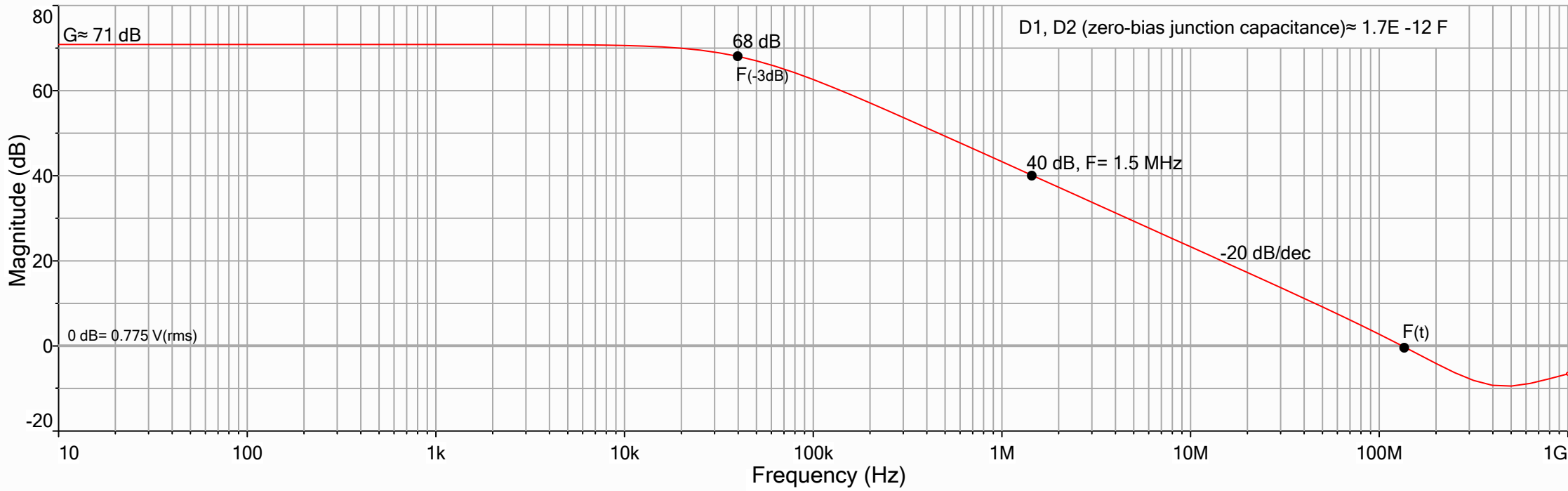

# Transitional characteristic

Small signal transient

F= 100 kHz

P<sub>(out)</sub>= 10 mW

R<sub>(L)</sub>= 8 Ω

nFB №2 (R2,R6), F<sub>(t)</sub> φ ≈ 35° (lagging phase)

Correction of the shape of a low-signal

Combined feedback

Classical feedback

Rectangular pulse generator (meander)

\* Piecewise - linear approximation of the graph line

Break in the negative feedback loop of the amplifier

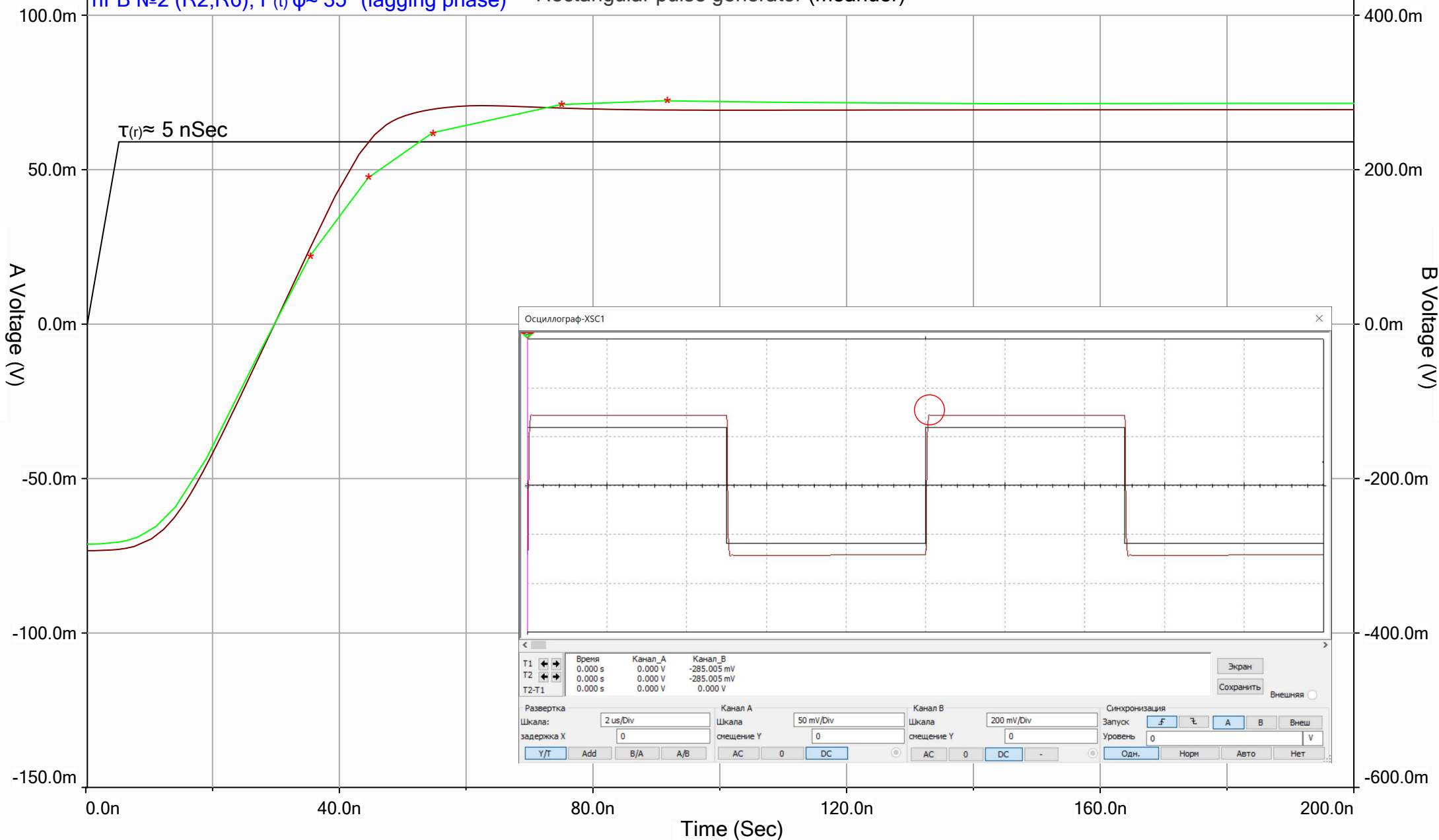

# Transitional characteristic

Figure 5

Large signal transient

$F = 100 \text{ kHz}$

$P_{(out)} = 8 \text{ W}$

$R_{(L)} = 8 \Omega$

nFB №2 (R2,R6),  $F(t) \varphi \approx 35^\circ$  (lagging phase)

Correction of the shape of a large signal

Combined feedback

Classical feedback

Rectangular pulse generator (meander,  $\tau(r) \approx 5 \text{ nSec}$ )

\* Piecewise - linear approximation of the graph line  
Break in the negative feedback loop of the amplifier

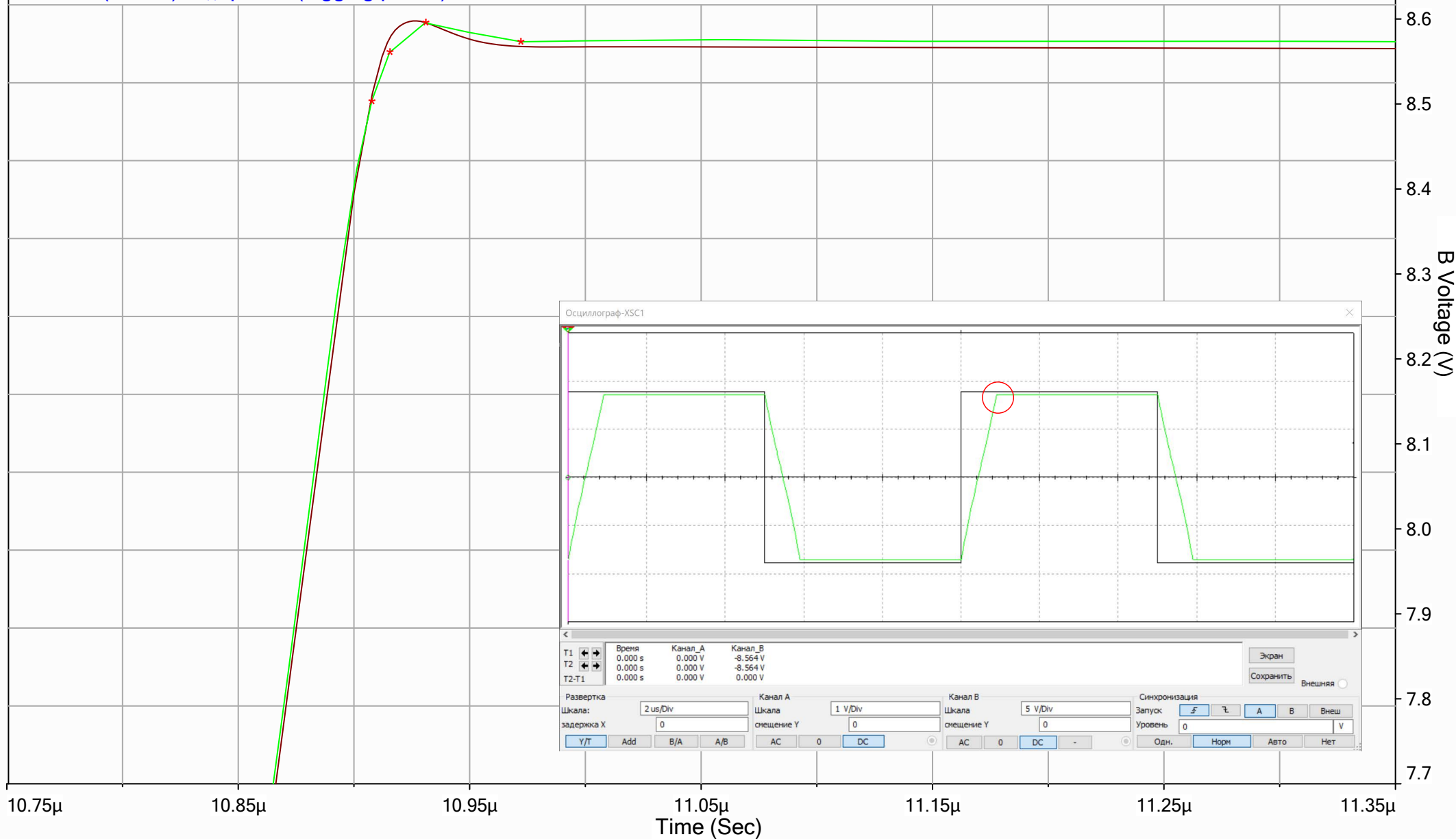

# Temperature gradient Q2,Q4 $I_{(D)}$ vs $t(^{\circ}C)$

Figure 6

