

Audio amplifier Zita (Z) bridge NEW

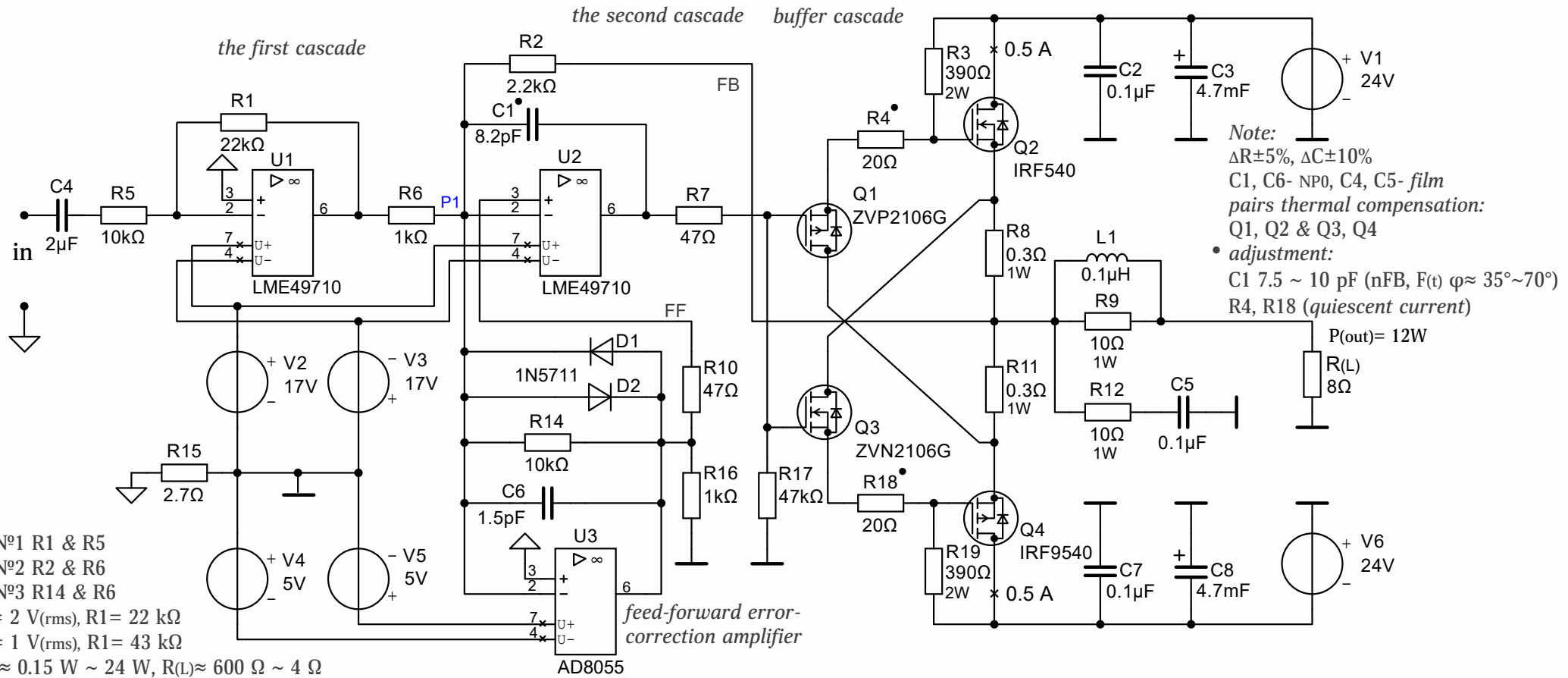

Features:

- high fidelity audio operational amplifier LME49710
- feed-forward error-correction amplifier AD8055
- buffer cascade (Q1~ Q4) "bridge+1\2 bridge, class- A"
- smart overload protection "step by step" (SoP)
- ripple rejection < -100 dB power supply

Key specifications:

$F_{(-3dB)} 10 \text{ Hz} \sim 10 \text{ MHz}$
 $F_{(-1dB)} 15 \text{ Hz} \sim 6 \text{ MHz}$
 $F_{(\varphi < 30^\circ)} 15 \text{ Hz} \sim 2.7 \text{ MHz}$
 $P_{(-3dB)} 10 \text{ Hz} \sim 450 \text{ kHz}$
Note:
 $P_{(out)} \approx 10 \text{ W}$, $R_{(L)} = 8 \Omega$

$P_{(out)} > 3 \text{ W}$ (buffer, class- AB)
 $P_{(out)} \leq 3 \text{ W}$ (buffer, class- A)
 $\text{THD} \leq 0.001 \%$ (10 Hz~10 kHz)
 $\text{SINAD} \approx 93 \text{ dB}$ (10 μW~10 W)
 $P_{(out)} \approx 15 \text{ W}$, max. (THD ≈ 1%)

SPICE
Models

ID: 8144715A



submit
documentation feedback

A two-stage power amplifier for speakers and stereo phones.

The first cascade. U1

Inverting voltage amplifier.

G~ 7 dB

Z(in)~ 10 kΩ

F(-3dB) 10 Hz ~ 23 MHz

F(t)~ 40 MHz

The second cascade. U2 U3 Q1~ Q4

Inverting voltage amplifier (U2), error voltage amplifier (U3).

U2

G~ 7 dB

Z(in)~ 1 kΩ

F(-3dB)~ 13 MHz

F(t)~ 21 MHz

U3

G~ 71 dB

F(-3dB)~ 40 kHz

F(t)~ 150 MHz

The error voltage from point "P1" is amplified, inverted by U3 and summed with the voltage at point "P1" in the differential cascade U2.

The error correction amplifier increases the gain in the loop (LG) to LG+71 dB, F(-3dB)≈ 40 kHz.

The diode limiter (D1,D2) reduces the gain in the error correction amplifier (U3) and U2 with significant signal addition errors at the point "P1".

Addition errors at point "P1" will occur when the input amplifier is overloaded or when complex signals are amplified (meander).

Buffer cascade (Q1~ Q4)

G~ -0.9 dB

Z(in)~ 47 kΩ

F(-3dB)~ 40 MHz

P(-3dB)~ 3.5 MHz

The "bridge+ 1/2 bridge" circuit operates with a quiescent current of 0.5 A in the "class- A" mode, P(out)≤ 3 W, R(L)= 8 Ω.

Parametric voltage regulator V2~V5.

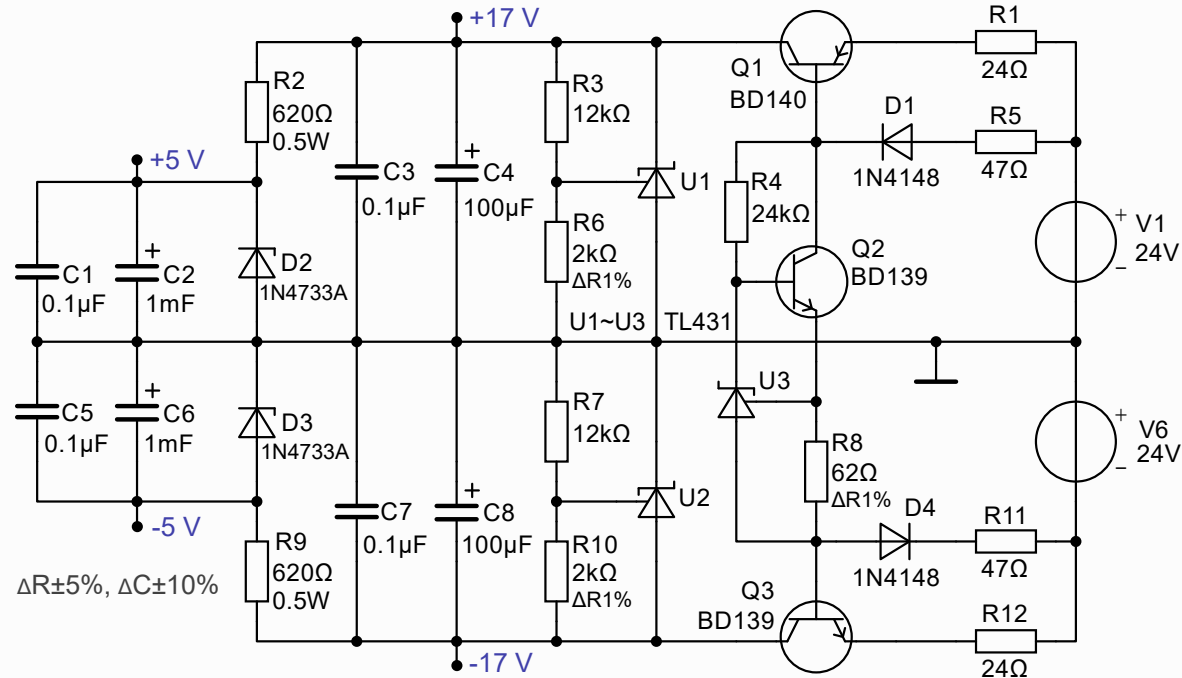

Bipolar power supply with parametric voltage stabilization, calculated value of the voltage attenuation value interference (ripple rejection) < -100 dB in the bandwidth of voltage stabilization channels.

Short circuit protection of the stabilizer output.

High precision output voltage (U_{REF(dev)}= 2.495 V±3 mV (type.)) and good thermal stability (αU_(ref)< 50 ppm/°C) reference voltage sources in a wide range of temperature values.

The value of the dynamic and static output impedances of voltage regulators Z_(ka)< 0.22 Ω (type.).



Audio amplifier Zita (Z) bridge

*A power amplifier with combined feedback (FB & quasi-FF).**

The use of combined feedback improves the technical characteristics of the amplifier.

Voltage feedback (FB) works well in stationary mode, when amplifying smooth-shaped signals (sinusoidal signal).

Direct voltage coupling (FF) works well in non-stationary mode, when complex signals of a non-smooth shape (meander) are amplified.

Advantages:

Expansion of the effective bandwidth of the amplifier ($F(-3dB)$).

Improvement of the impulse response of the amplifier.

Reduction of nonlinear distortion (THD) and intermodulation distortion (IMD).

Increasing the stability of the amplifier to the reactive impedance of the load ($C(L)$).

Improving the stability of DC operating points in the amplifier stages.

Bandwidth $F \approx 2.7$ MHz with a phase shift of $< 30^\circ$ and good low-signal linearity makes it possible to amplify up to $F \approx 10\sim 20$ kHz almost the full spectrum of smooth signals with minimal changes in their spectral composition.

The diode limiter (D1,D2) eliminates overload of the amplifier stages in case of short breaks in the feedback loop (nonlinear cascade operation) and overload of the input signal.

The error amplifier (U3) operates with a gain of $G \approx 70$ dB in linear mode of operation of the amplifier, in overload mode the gain decreases exponentially and amounts to $G \ll 0$ dB.

Tracking Trend

** Additional information is provided in the publication:*

"Feedforward error correction in power amplifiers. J. Wanderkooy".

Zita (Z) simplified architecture

the first cascade the second cascade buffer cascade

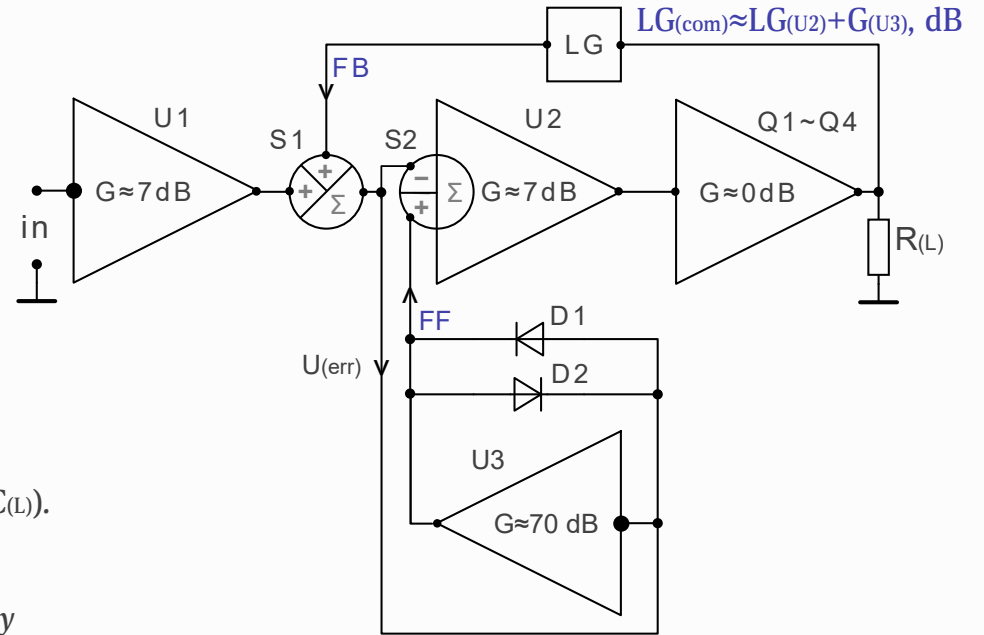

feed-forward error-correction amplifier

S1- adder, point "P1" (nFB №2 R2 & R6)

S2- U2, differential stage works as a adder

U(err)- error voltage, point "P1"

G- the voltage gain factor

LG- feedback loop gain

Note:

Direct communication is located inside the feedback loop.

Smart overload protection (SoP)

Zita (Z) architecture SoP Block diagram

Performing the "step by step" procedure allows you to correct errors in the feedback loop more effectively and improve the accuracy of signal amplification.

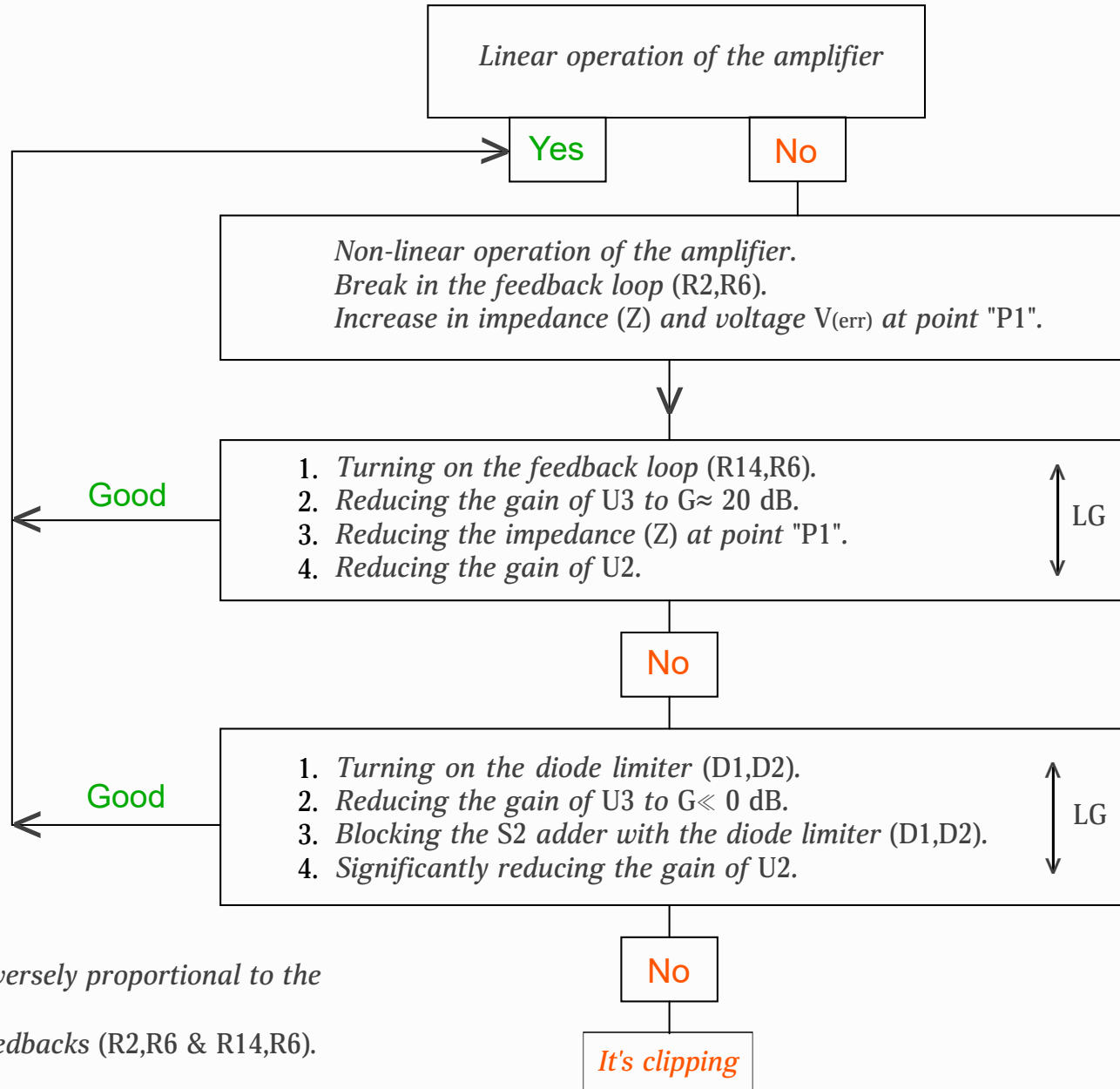

Note:

The impedance (Z) at point "P1" is inversely proportional to the gain in the feedback loop.

Point "P1" will be common to both feedbacks (R2,R6 & R14,R6).

LG- Feedback loop gain.



Spectrum analysis

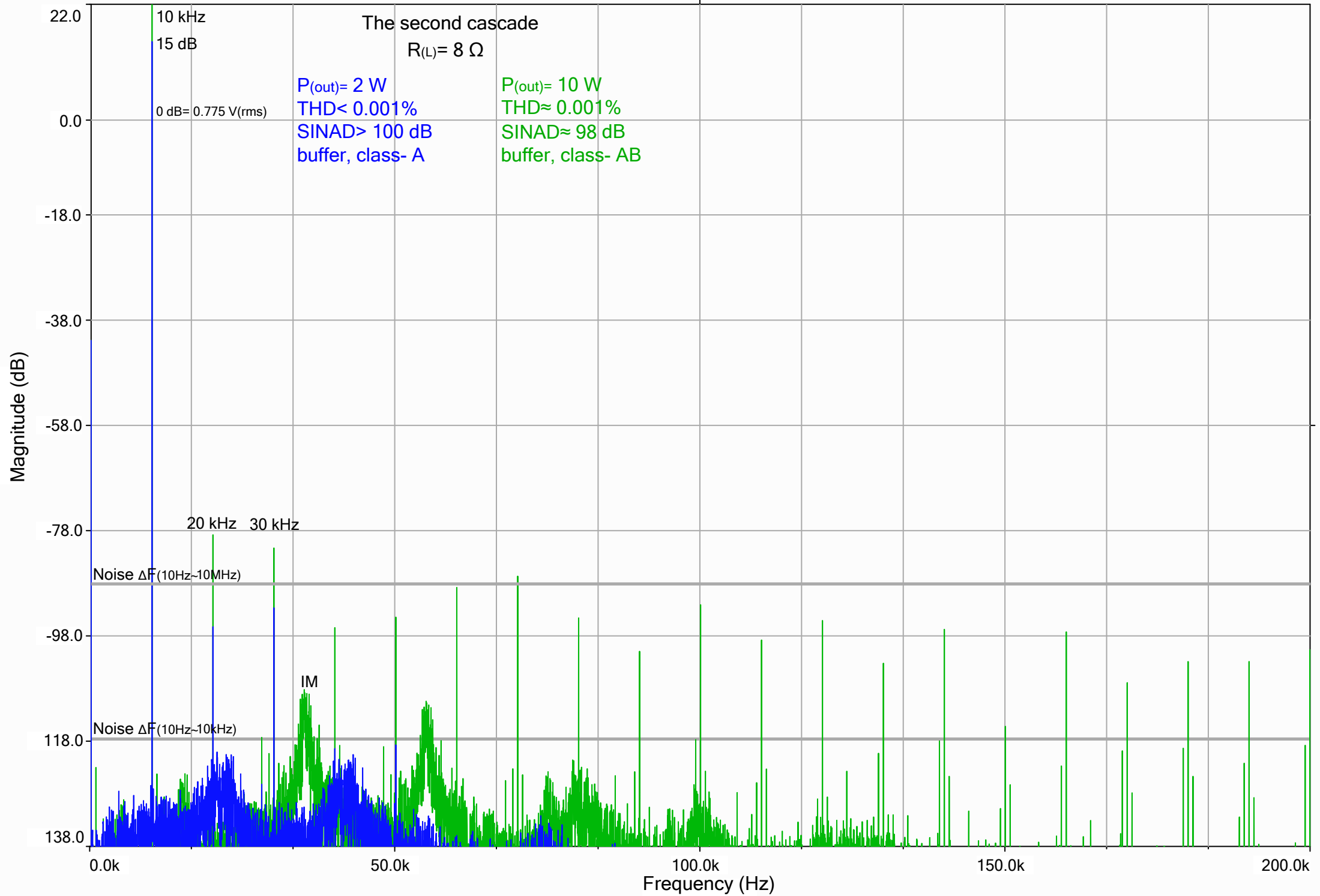

AC Sweep Open loop gain (OLG)

$$\frac{\Delta U_{(out)}}{\Delta U_{(in)}}$$

Figure 2

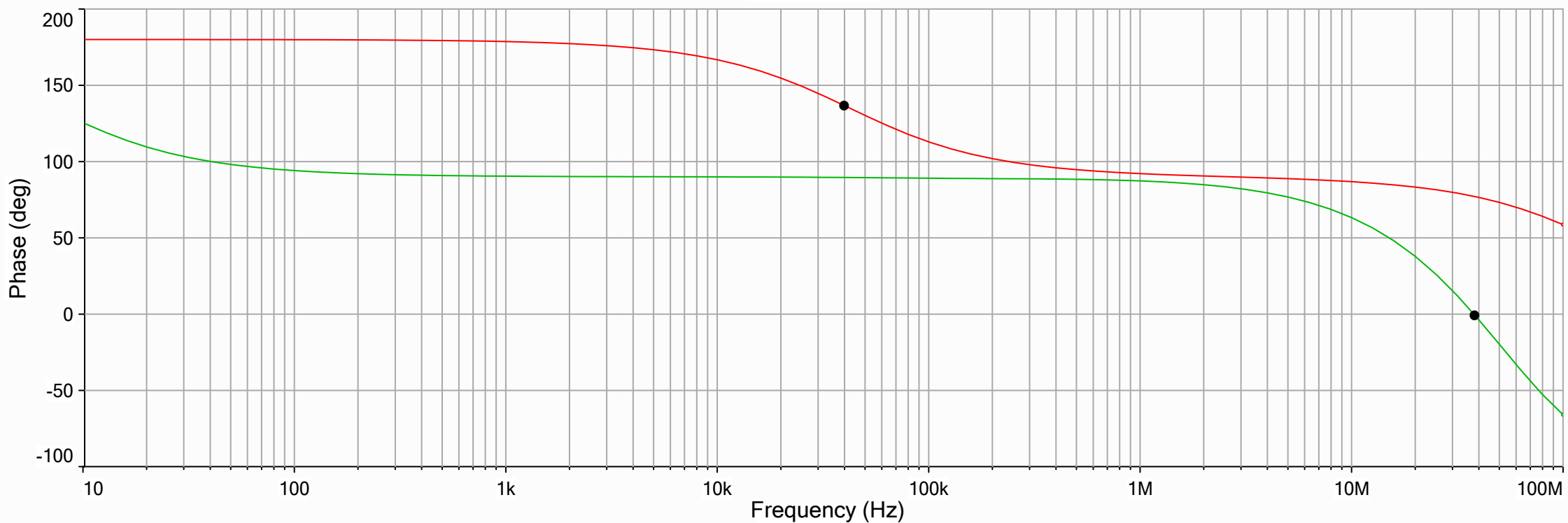
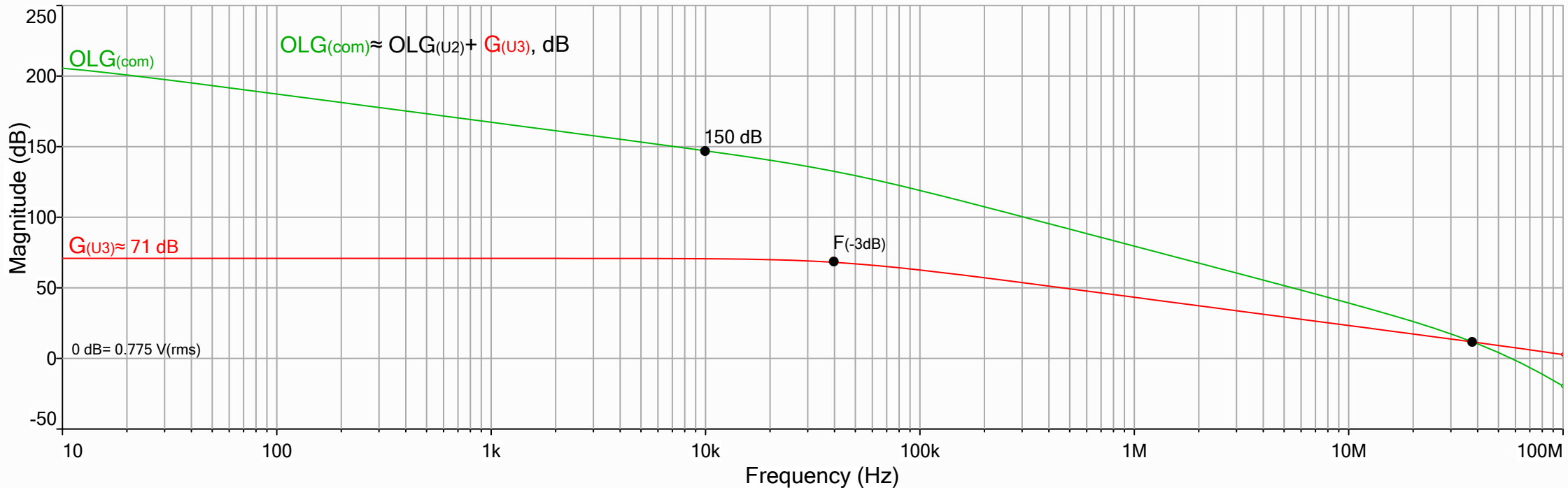

AC Sweep Error-correction amplifier U3

$$\frac{\Delta U_{(out)}}{\Delta U_{(in)}}$$

Figure 3

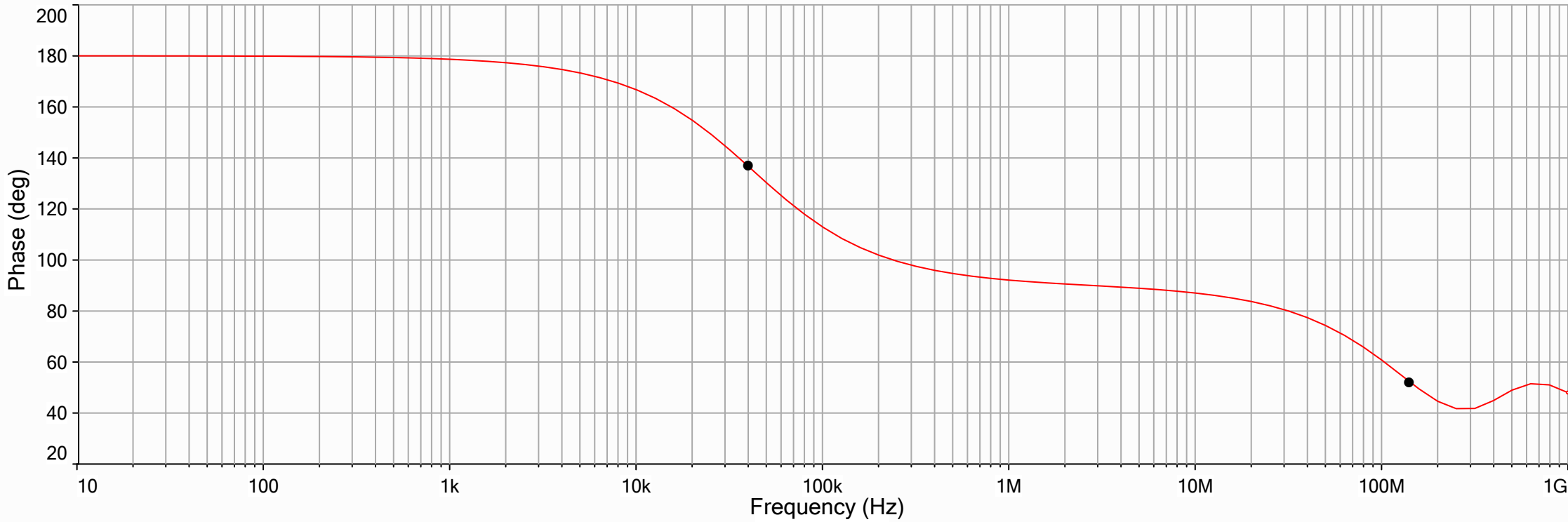
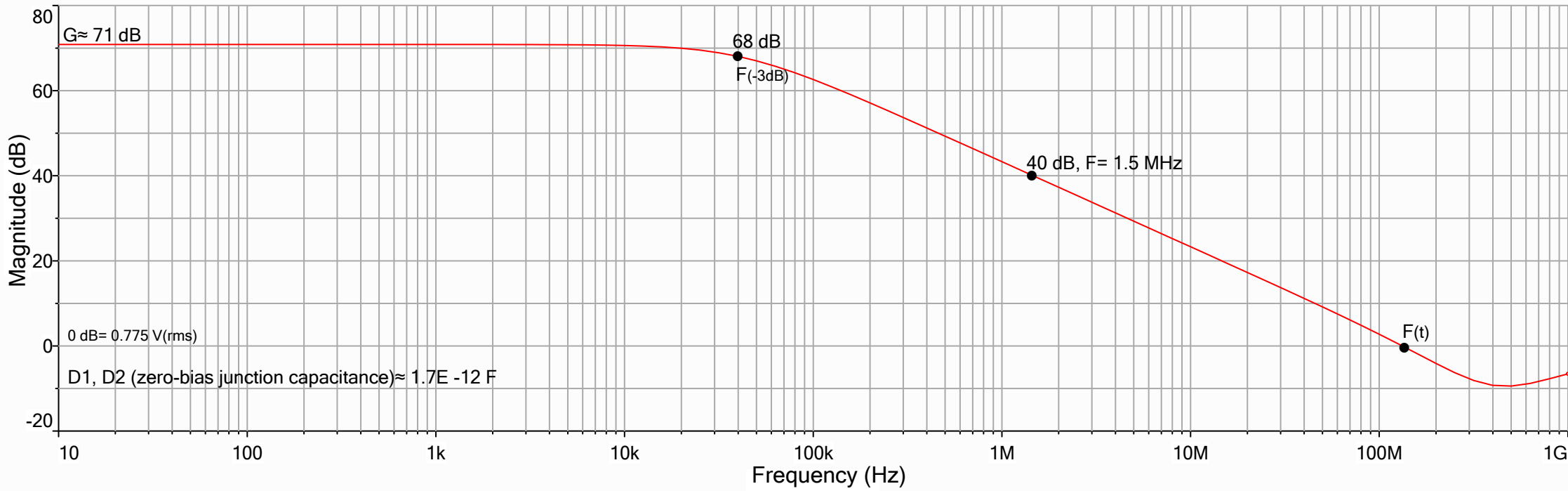

Transitional characteristic

Figure 4

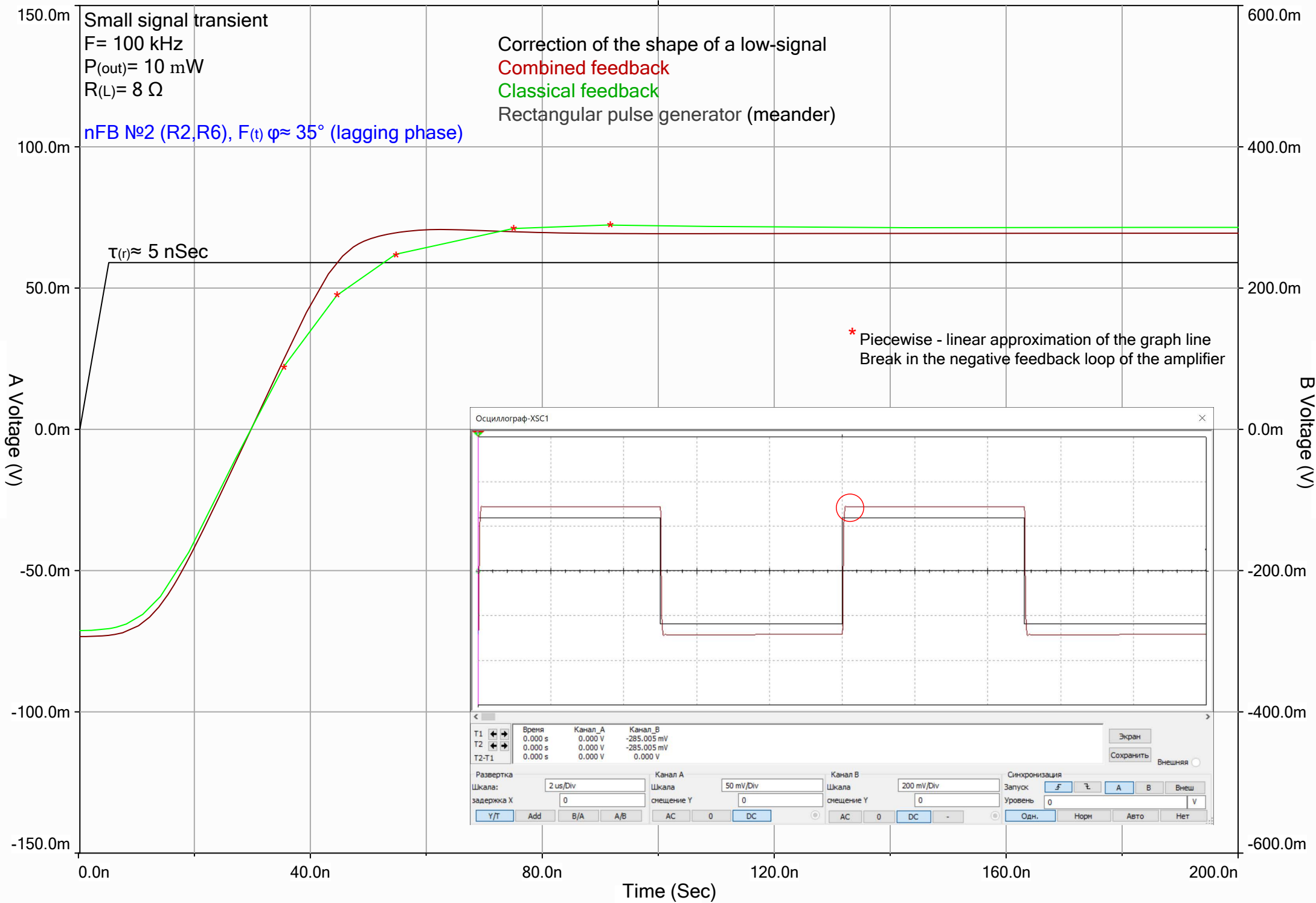

Transitional characteristic

Figure 5

Large signal transient

$F = 100 \text{ kHz}$

$P_{(out)} = 8 \text{ W}$

$R_{(L)} = 8 \Omega$

nFB №2 (R2,R6), $F(t) \varphi \approx 35^\circ$ (lagging phase)

Correction of the shape of a large signal

Combined feedback

Classical feedback

Rectangular pulse generator (meander, $\tau_{(r)} \approx 5 \text{ nSec}$)

* Piecewise - linear approximation of the graph line
Break in the negative feedback loop of the amplifier

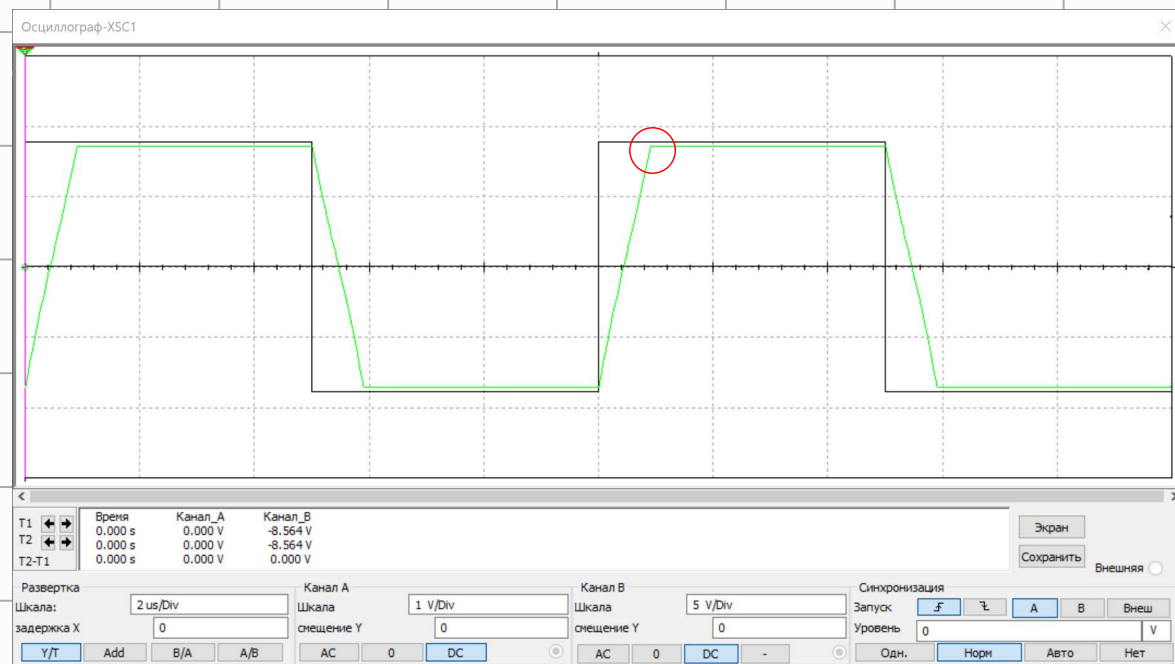

10.75μ

10.85μ

10.95μ

11.05μ
Time (Sec)

11.15μ

11.25μ

11.35μ

B Voltage (V)

8.8
8.7
8.6
8.5
8.4
8.3
8.2
8.1
8.0
7.9
7.8
7.7

Temperature gradient Q2,Q4 $I_{(D)}$ VS $T(^{\circ}C)$

Figure 6

