

**What do you get when you mate a power amplifier IC with a precision op-amp?
Answer: a "turbocharged" audio amplifier.**

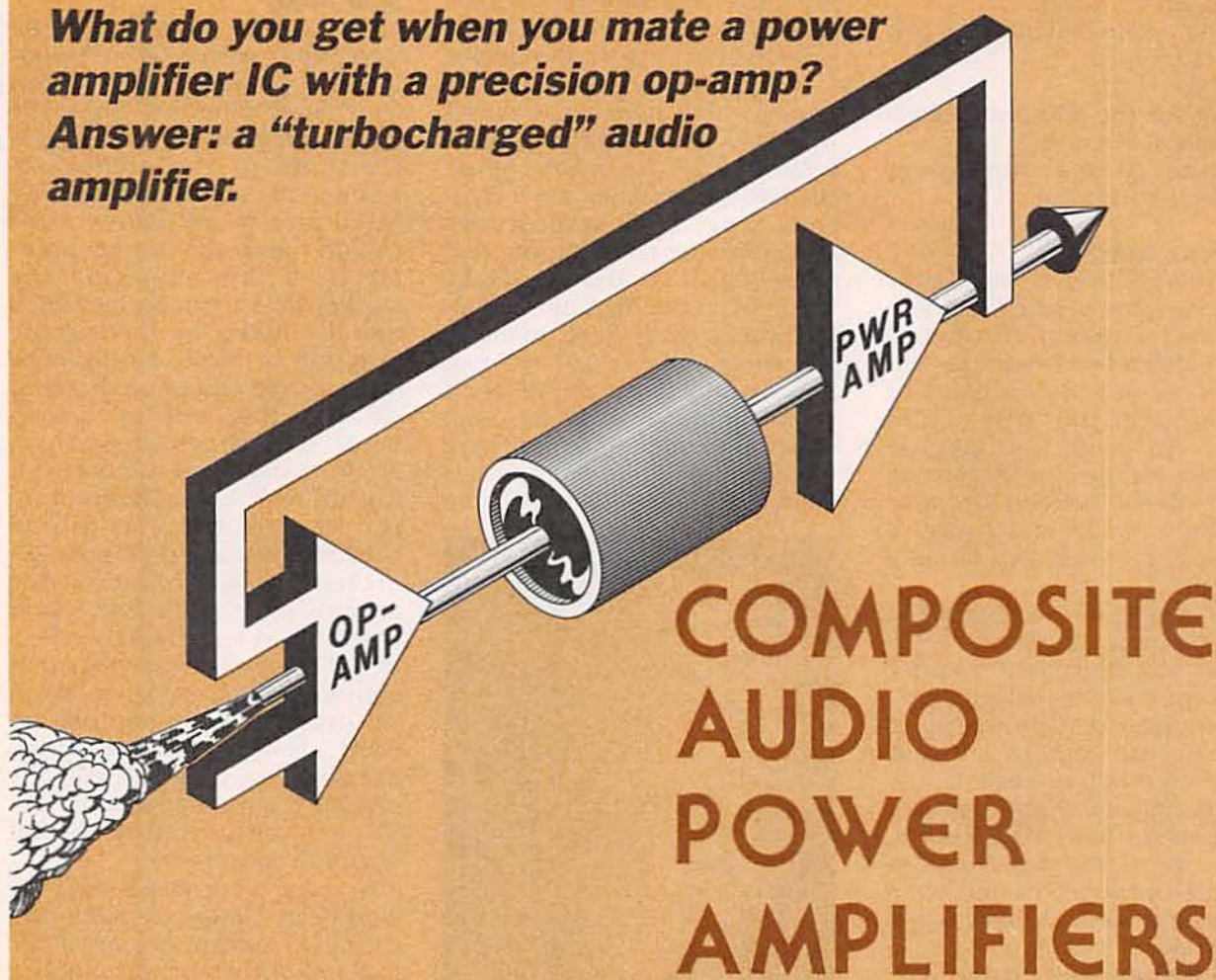

CHARLES KITCHIN, SCOTT WURCER, AND JEFF SMITH

NOW YOU CAN BUILD YOUR OWN high-performance audio amplifiers from inexpensive components and beat the high price of factory-made amplifier modules. The composite amplifiers described here can improve stereo systems and other audio equipment with moderate power output. As you read this article you will probably be able to think of many applications for these circuits.

The five souped-up audio amplifiers are made by inserting monolithic power amplifiers in the feedback loops of operational amplifiers. The "turbocharged" composites retain the low distortion and offset of the op-amps and the high-current handling capability of the power amplifiers.

The amplifiers described here are: two simple 10-watt com-

posites, a 33-watt bridge composite, a 40-watt composite with a single-ended summing connection, and a 70-watt composite with two current-summing amplifiers in a bridge configuration. The output power values of all circuits are in root-mean-square (rms) watts.

Figure 1 is the pinout and functional diagram for the Analog Devices AD711JN, the precision, high-speed op-amp that is a part of all the composite amplifiers described here. The op-amps include both bipolar and field-effect transistors fabricated in a process known as BIFET technology. The pinout diagram is for plastic and ceramic DIP's.

Figure 2 is the pinout diagram for the National Semiconductor LM1875, the 20-watt power audio amplifier (power

amp) in all of the composite amplifiers in this article. It is packaged in a flat-pack plastic TO-220 case.

Single-unit or low-volume prices on the op-amps and power amplifiers are subject to wide variations among the various vendors. However, calculations based on components from nationally advertised sources show the cost of the composites to be quite low. The component costs for each composite amplifier (except for power supply) were summed and divided by the amplifier's rated output power, and the results averaged out to be less than \$1 per watt.

A 10-watt composite

Figure 3 shows the basic composite amplifier circuit with IC2, an LM1875, in the feed-

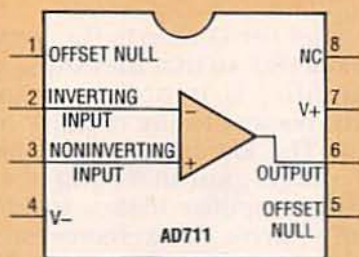

FIG. 1—PINOUT AND FUNCTIONAL BLOCK DIAGRAM for the AD711JN operational amplifier in an 8-pin DIP.

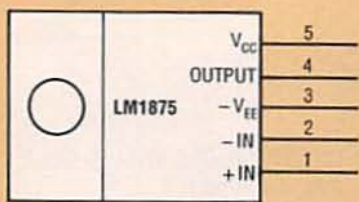

FIG. 2—PINOUT DIAGRAM for the LM1875 amplifier in a TO-220 case.

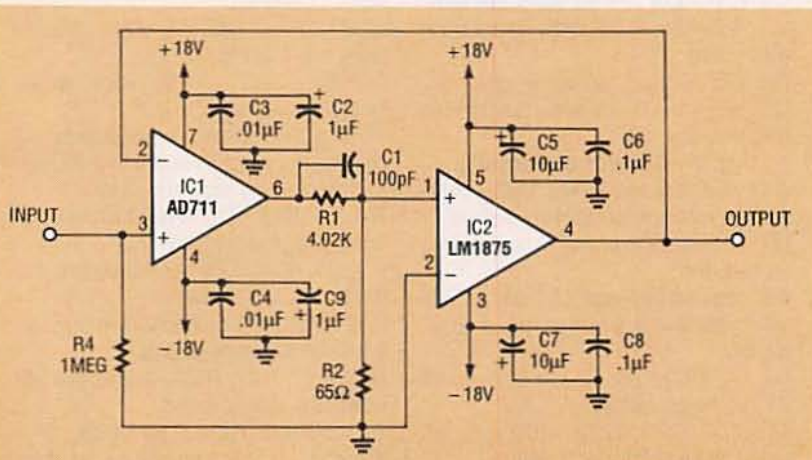

FIG. 3—A 10-WATT NON-INVERTING COMPOSITE AMPLIFIER

back loop of IC1, an AD711JN. The circuit is a non-inverting, high input-impedance, unity-gain follower. It delivers 10 watts rms into an 8-ohm load at 1 kHz, with a total harmonic distortion of less than 0.003%. Total harmonic distortion (THD), a figure of merit for an amplifier, is the total root-mean-square (rms) harmonic voltage in a signal, as a percentage of the voltage at the fundamental frequency. THD should be as low as possible. The maximum offset voltage of this amplifier is 1 millivolt.

The basic composite circuit can also be configured as a low input-impedance inverting amplifier as shown in Fig. 4. That

duces more distortion when it is connected as a follower (Fig. 3) because of its large common-mode signal.

Both IC's are operating within the same loop in Fig. 4, so a phase-lead network, consisting of capacitor C1 and resistors R1 and R2, provides the necessary compensation to stabilize the response of both the AD711JN and the LM1875. This network can be tailored for specific applications by providing a trade-off between bandwidth and phase margin as listed in Table 1.

The THD values given for these circuits include both distortion and noise. At low frequencies, noise is the predomi-

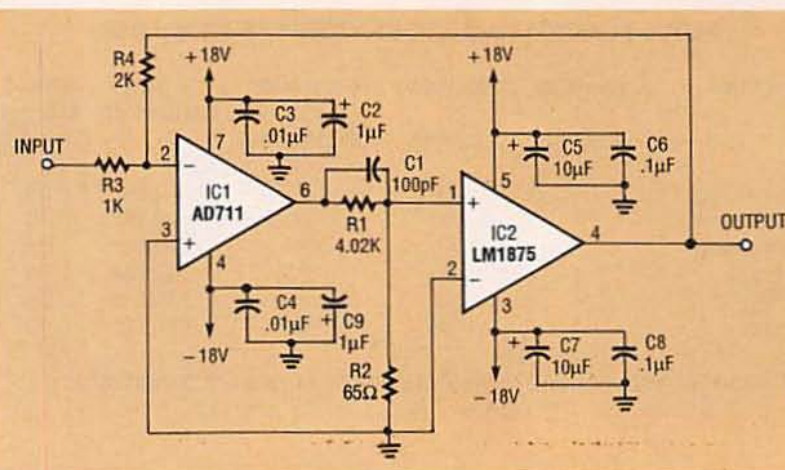

FIG. 4—A 10-WATT INVERTING COMPOSITE AMPLIFIER.

nant error source; at higher frequencies, distortion will increase because of the finite open-loop gain of the amplifiers. Even with this frequency-related increase, THD remains extremely low over the entire audio range.

When functioning independently, the THD of the LM1875 power amplifier vs. power output peaks at about 0.5 watt. It produces about 0.05% THD into an 8-ohm load and 0.1% THD into a 4-ohm load at this power level. That variation in THD vs. power level is characteristic of thermal feedback on the IC chip. It is also one of the benefits of thermally isolating an external amplifier within a feedback loop.

FET-input op-amps with low first-stage transconductance (such as the AD711JN) tolerate a larger voltage swing on their inputs than bipolar op-amps without producing the characteristic bipolar op-amp overload distortion. When open-loop gain decreases, producing a larger error on the summing junction, a FET-input op-amp behaves more linearly than a bipolar op-amp, making it the optimum choice as the control amplifier in composite circuits.

Step response is an important consideration in many audio-amplifier applications. The composite amplifiers described here take advantage of the performance features of the AD711JN. For example, the AD711JN has twice the slew rate of the LM1875; if the AD711JN

TABLE 1—PERFORMANCE VS. COMPONENT VALUES

Connection	Resistor 1 (Kilohms)	Resistor 1 (Ohms)	Capacitor 1 (Picofarads)	-3dB Bandwidth	Phase Margin (Degrees)
Non-inverting	4	200	30	1.77MHz	35
Non-inverting	4	100	68	1.58MHz	70
Non-inverting	4	65	100	1.34MHz	85*
Inverting	4	400	30	1.8MHz	25
Inverting	4	200	68	1.6MHz	25
Inverting	4	80	100	890kHz	90*

*Best transient response and highest stability at expense of bandwidth

were slower, the LM1875 could overshoot significantly before it is corrected by the AD711JN. On the other hand, if the AD711JN were much faster than the LM1875, the driver would slew to the supply rail before the buffer could respond.

Higher power composites

The composite circuit concept can be expanded by connecting two or more of them together. High-power amplifiers normally include discrete transistors with high breakdown voltages (typically over 100 volts) and high current-handling ability. Small IC power amplifiers have breakdown voltages in the 30- to 50-volt range. Maximum power delivered to the load is directly related to the supply voltage.

A bridge configuration applies power to the load differentially. Therefore, it can provide twice as much driving voltage to the load as a parallel or current-summing configuration. This permits higher power output from a given supply voltage (assuming that the increased current demand can be met). Also, the slew rate delivered to the load is greater than the slew rate of either of the two IC driving amplifiers.

33-watt composite bridge

The circuit shown in Fig. 5 combines two non-inverting composite amplifiers, A and B, in a bridge or differential output connection. It operates with an overall gain of 30 and it provides 33 watts rms to an 8-ohm load with less than 0.002% THD at 1

kHz. Amplifier C is a DC servo amplifier.

Amplifier D inverts the input signal 180° so that the output of amplifier B is non-inverting with respect to the circuit's input. The low input-impedance of a high-gain inverting composite amplifier makes it difficult to drive. To overcome this, two non-inverting composite amplifiers have been configured as a bridge amplifier, and one of them is driven with a single op-amp inverter.

PARTS LIST

Figs. 3 and 4—10-watt composite amplifiers

All capacitors are 5%, 50 volts, silvered-mica except as stated below.

C3, C4—0.01 μ F, 50 volts, ceramic
C5, C7—10 μ F, 35 volts, aluminum electrolytic
C6, C8—0.1 μ F, 50 volts, ceramic
C2, C9—1 μ F, 35 volts aluminum electrolytic

Fig. 5—33-watt composite

All resistors are 1/4-watt, 5%, metal-film except as stated below.
R7, R15—1,500 ohms, 5-watt, 20%, wirewound

All capacitors are 50 volts, 5%, silvered-mica except as stated below

C2, C3, C10, C11, C14 to C17—0.01 μ F, 50 volts, ceramic
C5, C7, C20, C22—100 μ F, 35 volts, aluminum electrolytic
C6, C8, C21, C23—0.1 μ F, 50 volts, ceramic
C25—C32—1 μ F, 35 volts, aluminum electrolytic
C9, C13—0.47 μ F, 20 %, 50 volts, polypropylene
C12, C24—0.27 μ F, 20 %, 50-volt mylar

Fig. 7—40-watt composite

All resistors are 1/4-watt, 5%, metal-film except as stated below
R6, R8—1000 ohms, 1/4-watt, 1 %, metal film

R7, R16—2000 ohms, 1/4-watt, 1%, metal film
R11, R17—1 ohm, 5-watt, 20%, wirewound
R12, R18—0.33 ohm, 5-watt, 5%, wirewound

All capacitors are 50 volts, 5%, silvered-mica except as stated below

C2, C3, C7, C8, C15, C16—0.01 μ F, 50 volts, ceramic
C10, C12, C18, C20—100 μ F, 35 volts, aluminum electrolytic
C11, C13, C19, C21—0.1 μ F, 50 volts, ceramic
C23—C28—1 μ F, 35 volts, aluminum electrolytic
C4, C5—0.47 μ F, 50 volts, 20%, polypropylene

Fig. 8—70 watt-composite

All resistors are 1/4-watt, 5%, metal-film except as stated below

R4, R8, R23, R27—1000 ohms, 1/4-watt, 1%, metal film

R5, R9, R24, R28—2000 ohms, 1/4-watt, 1%, metal film

R12, R16, R31, R35—1-ohm, 5-watt, 20%, wirewound

R13, R17, R32, R36—0.33 ohm, 4-watt, 5% wirewound

All capacitors are 50 volts, 5%, silvered-mica except as stated below

C3, C4, C7, C8, C14, C15, C22, C23, C26, C27, C30, C31, C37, C38,—0.01 μ F, 50 volts, ceramic

C10, C12, C18, C20, C33, C35, C40, C42—100 μ F, 35 volts, aluminum electrolytic

C11, C13, C18, C20, C34, C36, C41, C43—0.1 μ F, 50 volts ceramic

C46—C57—1 μ F, 35 volts, aluminum electrolytic

C2, C5, C25, and C28—0.47 μ F, 50 volts, 20%, polypropylene

All semiconductors are Analog Devices AD711JN and National Semiconductor LM1875

Note: AD711JN's are available in single quantities from Active Electronics, Woburn, MA 01801,

and LM1875's are available from several *Electronics Now* advertisers.

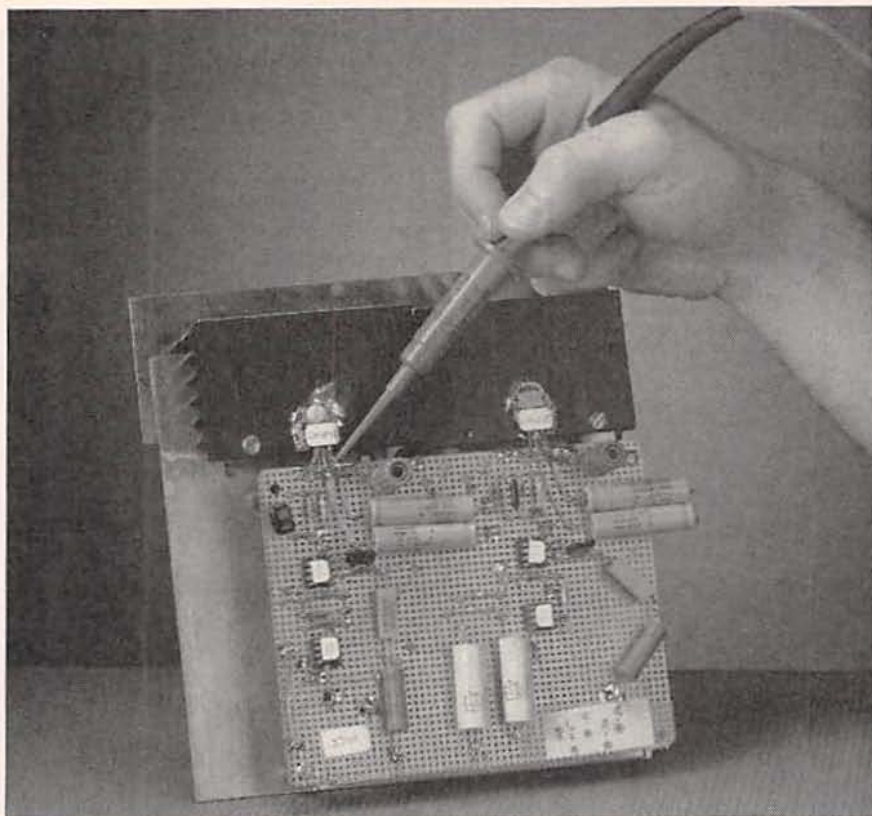

FIG. 6—THE AUTHORS' PROTOTYPE FOR THE 33-WATT composite amplifier. The two LM1875's are on the black heat sink at top, and the four AD711's are the white patches in a square pattern on the circuit board.

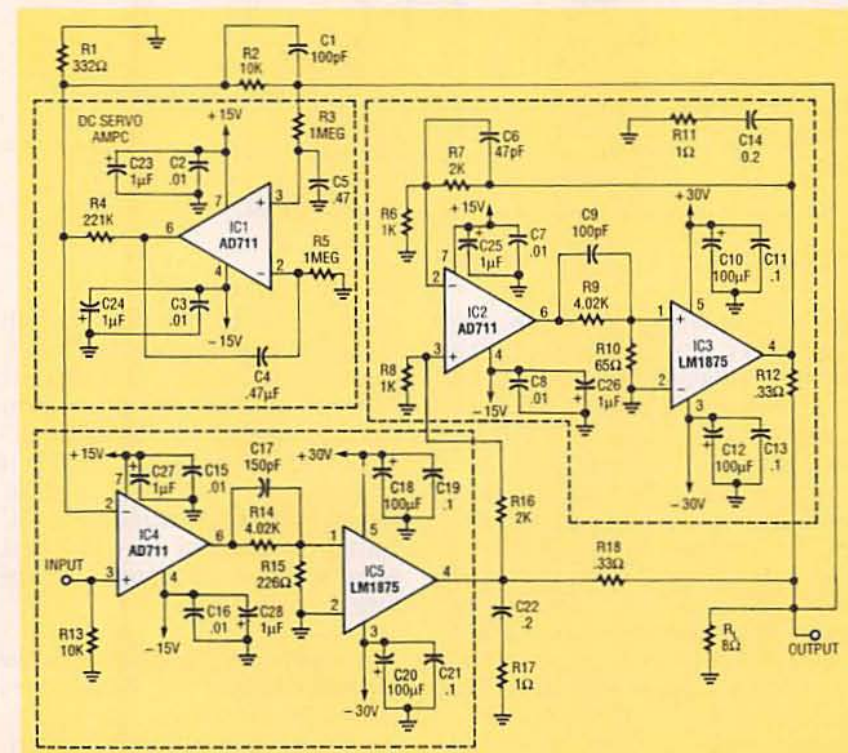

FIG. 7—A 40-WATT COMPOSITE AMPLIFIER that includes a single-ended summing connection.

phase inversion is needed because the two outputs are simply added together. Amplifier C

is a DC servo that differs from its counterpart in Fig. 5 because its input is referenced to

ground. It connects to the inverting input of amplifier B, and nulls any DC offset at that composite's output.

The circuit of Fig. 7 delivers slightly more power than the bridge circuit of Fig. 5, but the bridge circuit has a faster slew rate. The circuit of Fig. 7 also has its output referenced to ground. It delivers 40 watts rms with less than 0.0029% THD at 1kHz into an 8-ohm load.

A 70-watt composite amplifier

The circuit of Fig. 8 delivers 70 watts rms into an 8-ohm load at 1 kHz with only 0.003% THD. It combines two of the current-summing amplifiers of Fig. 7 in a bridge. The current-summing amplifiers give the necessary high output-current handling capability. A differential output is obtained by connecting the two pairs of current-summing amplifiers in the bridge configuration that allows the composite to drive ± 34 volts into a 8-ohm load.

Two DC servos keep the DC output voltage at both output pins at zero. As with the other circuits described here, any offset would cause the amplifier to lose "headroom" or clip unsymmetrically.

Figure 9 shows the authors' prototype 70-watt composite amplifier. Four AD711's are shown as white blocks on the circuit board (lower left), and three more are shown on the circuit board at lower right. The four LM1875's are shown in a horizontal row on the heat sink (gray area) above the circuit boards.

Figure 10 is a graph showing THD (including noise) vs. power output plotted from the authors' breadboard versions of the circuits described in this article. For comparison purposes the plot of THD vs. power output for the LM1875 as a stand-alone device has been taken from the National Semiconductor data.

Building the amplifiers

These circuits can be built with dual or quad versions of the AD711 if you want to save board space. The AD711JN met all of the op-amp requirements,

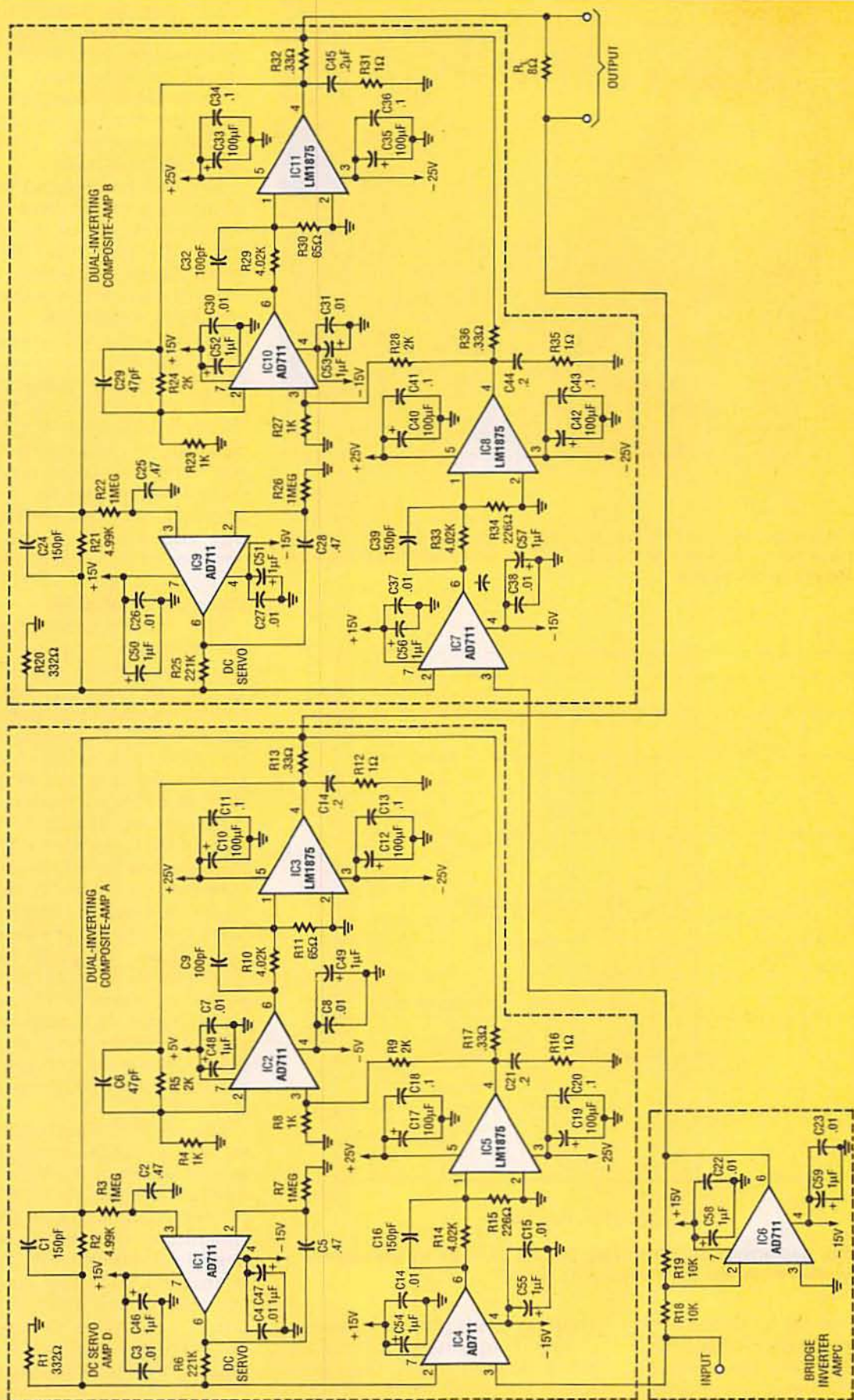

FIG. 8—A 70-WATT COMPOSITE AMPLIFIER

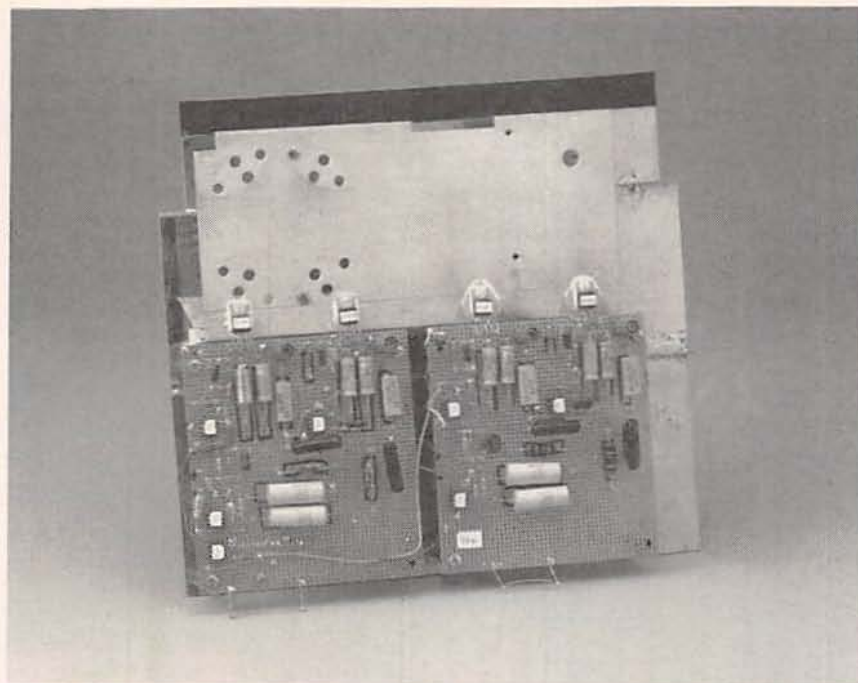

FIG. 9—THE AUTHORS' PROTOTYPE FOR A 70-WATT composite amplifier. The four LM1875's are in a row on the heat sink at the top, and the seven AD711's are the white patches on the two circuit boards.

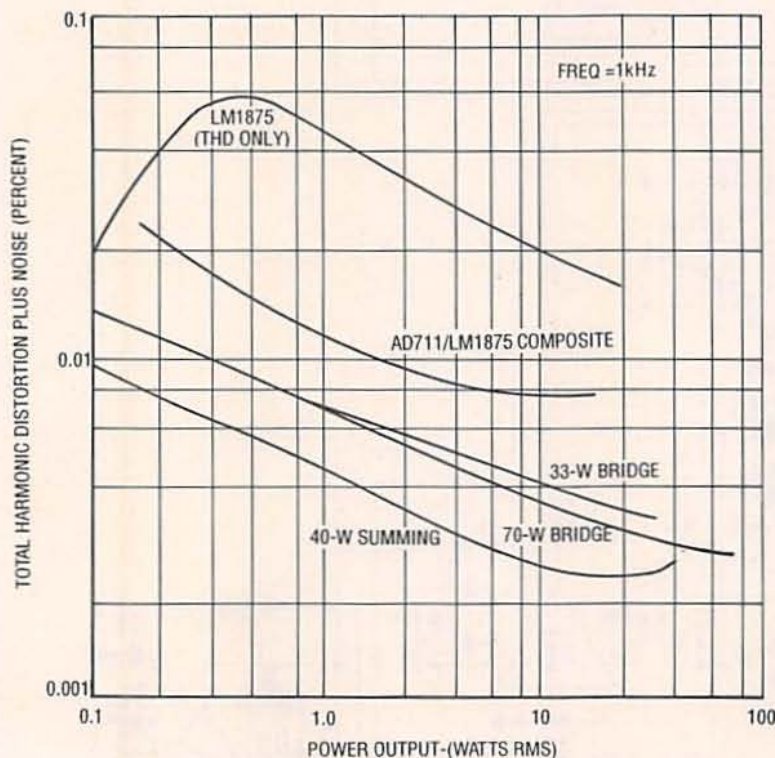

FIG. 10—TOTAL HARMONIC DISTORTION vs. POWER OUTPUT for the composite amplifiers described in the text and a stand-alone LM1875.

but additional components might be needed for circuit stability if other op-amps are substituted. The Parts List specifies the components selected for op-

imum circuit performance.

The composites have amplifiers within their feedback loops, so the differing frequency response poles of each amplifier

could interact, causing circuit instability. Therefore, proper grounding and component layout are important. Build all circuits on a ground plane. Inadequate circuit grounding and layout can increase THD by an order of magnitude.

Keep all component leads as short as possible, and connect signal grounds to the ground plane. The plane and the power grounds are tied to the common connection of the power supply's filter capacitors.

Power supply bypassing is important in these circuits. Locate the by-pass capacitors as close as possible to the IC's when building the circuits. Separate all high-current carrying wires or other conductors from low-current or high-impedance conductors. Keep input and output leads as far apart as board space will allow.

The power supplies

The circuits must operate at the specified voltages to reach the power levels stated here. Those are typically ± 25 -volts DC for the LM1875 power amplifiers and ± 15 -volts DC for the AD711JN's. The highest power output is reached when the LM1875's are powered from ± 30 -volt-DC (their maximum safe rating), and the AD711JN's are powered by ± 15 volt-DC.

Mount all LM1875's on heat-sinks, but use an oversize heat-sink when operating any LM1875 at ± 30 volts, its maximum limit. The LM1875 dissipates 2 watts with an idle current of 70 milliamperes at ± 15 volts. However, dissipation rises to 6 watts with an idle current of 100 milliamperes at ± 30 -volts.

The LM1875's limit the power supply voltage excursion of minus about 2.5 volts on top and bottom. For a ± 18 -volt supply the limit is about 15 watts rms into an 8-ohm load, and for a ± 15 -volt supply it is about 10 watts rms. Estimate your voltage requirements to obtain the power needed for any specific application. Remember that low supply voltages mean cooler running circuits and higher circuit reliability.

R-E